

AC 2007-1143: LEARNING EXPERIENCES OF USING TEACHING AND ASSESSMENT TOOLS FOR SOLID MECHANICS COURSE

Raghu Echempati, Kettering University

RAGHU ECHEMPATI is a Professor of Mechanical Engineering at Kettering University (formerly GMI Engineering & Management Institute). He has over 20 years of teaching, research and consulting experience. His teaching and research interests are in the areas of Mechanics, Machine design, and CAE (including metal forming simulation and Design of Machines and Mechanisms). He is very active in the Study Abroad Programs at Kettering University. He is a member of ASME, ASEE, and SAE, and a Fellow of the ASME.

Learning Experiences of Using Teaching and Assessment Tools for Solid Mechanics Course

Abstract

This paper describes the author's experiences of using a few teaching and assessment tools for Solid Mechanics course taught at Kettering University. This course is taught at junior level and is offered during all the four terms. Kettering University is a co-op institution in which the students alternate each term between work and school. This creates a time gap between the study and the work terms, posing some challenging issues for many students to retain the pre-requisites knowledge. It is very time consuming to review the pre-requisites knowledge to get the students back on track in either the Solid Mechanics or in the Machine Design courses. This paper describes the teaching and learning experiences of incorporating some of the teaching and assessment tools to improve the overall performance in the Solid Mechanics course. Some of these simple tools include reaching out the students during their work term by sending them the upcoming course review materials, implementing cooperative learning and project based learning through in-class group work and group homework, assignment of mini-projects, etc. It was observed that using some of these tools improved their overall understanding and better performance as measured by their scores on the final examination. The final examination questions have been carefully designed by a group of faculty teaching this course so that each question is tied with the course (or student) learning objectives (CLOs or SLOs) and the program outcomes (POs). Sample assessment charts are presented at the end of the paper and discussed.

Introduction and Literature Review

There is a lot of literature on educational research and teaching and learning techniques available that deal with improving Mechanics education. ASEE J. of Engineering Education, J. of Science, Math, Engineering and Technology (SMET) Education, J. of STEM, etc., are only a few of many such dedicated journals devoted to engineering education. Numerous textbook authors and the publishers have organized forums on college campuses and at several educational conferences such as ASEE to get a first hand feedback from both the teachers and some times from the learners of Mechanics courses. Therefore, the bibliography presented in this paper is no way complete. Only a few relevant papers are cited in this paper.

As mentioned by Krumsieg and Baehr¹, the teacher and the learner should be aware of the particular methods and skills that are used in each discipline and a course to advance learning and knowledge in those fields.

Bowe² et al discussed the results of *multimedia tools* using power point slides of finite element-based stress results to emphasize aspects of stress analysis which their students have traditionally found difficult to grasp. Their assessment showed that overall the students actually disliked the use of these tools for very concrete reasons and improvement in overall learning and comprehension was statistically insignificant. Based on these results, the authors modified their teaching methods to enhance the classroom environment.

Nathan³ developed a set of instructions after working for many years on transitioning from *chalkboard to integrating several multi-media aids* for classroom use. As many instructors would do, he began the transition from chalkboard to overlaid transparencies, which were later transferred to meaningfully animate electronic slides. These slides were then combined with fill-in worksheets for classroom use, along with the addition of streaming videos for asynchronous instructions. Qualitative feedback indicated a positive response from students.

In order to encourage and to promote student learning in-class assessment is a useful tool that actively involves students, while providing valuable feedback to the instructor. Immediate feedback can be even more beneficial, because the instructor can modify the presentation “on the fly” depending on the students’ levels of understanding. One currently available tool, the GTCO CalComp™ “Personal Response System” (PRS)⁴ has been used and by Moe while teaching the Fundamentals of Mechanics course. The goal of the analysis was to use emerging technology to enhance the learning environment in engineering courses by increasing instructor-student interaction through assessment and real-time feedback.

Elahinia and Ciocanel⁵ presented a *redevelopment method and process of the laboratory experiments* for the Mechanics and Vibration Laboratory in which the objective was to transform the learning process from a *subject-based learning* to a *problem-solving learning*. Particular objective was to provide the students with more hands-on experience and to challenge them by requesting the procedure for each laboratory experiment to be designed and carried out by each group of students. Their method was in line with the program objectives of their department.

Integration of *Concept Inventories* is another method used by many researchers in gauging student knowledge. The commonly employed metrics (such as homework, quizzes and exams) serve as indicators of student performance for instructors. However, these instruments may not truly help in assessing student knowledge gains. Steif and Dantzler⁶ conducted a study to design multiple choice questions in Statics course that helped them perform psychometric analysis of the test results of over 245 students at several different universities. They concluded that the inventory offers reliable and valid measures of conceptual knowledge in Statics course. On the basis of their test, one can infer which concepts students in general tend to have the most difficulties with, as well as the misconceptions that appear to be most prevalent.

The present author gave Steif's test as the Statics competency test. The results collected over three terms agree with Steif's findings about the students' understanding of the concepts and the misconceptions. Concept inventories have recently emerged as tools for assessing students' understanding of the basic concepts upon which technical education is based are being developed and validated for a variety of engineering subjects.

Steif and Naples⁷ developed Problem Solving Courseware Modules for Mechanics of Materials course. These modules are based on use of a computer that takes a complementary approach (compared to the textbooks) of enabling students to work with a limited set of configurations in great depth. Their conclusion based on a few years of evaluation was very positive in the sense that the student users were very enthusiastic about using the courseware as they viewed it beneficial to their learning.

As mentioned before, there are other numerous papers in the teaching methods, evaluation and assessment of Mechanics courses and how they improve the mechanics education. Therefore, this literature survey is by far not a comprehensive one.

Solid Mechanics Course

The Solid Mechanics faculty team at Kettering University met several times and agreed on a common syllabus that consisted of "Required Topics" to be covered and tested on common final examination, and topics that are "Optional" for coverage by the individual instructor and tested on home work, quizzes and midterm examinations. When once a common syllabus has been agreed up on, identifying the course learning objectives (CLOs or SLOs) has become an easier task. The goal was to have these CLOs simple and less in number. The following CLOs have been identified for this course along with the Mechanical Engineering Program Outcomes (ME POs) and weightage. Notice that the total weightage of the ME POs under each CLO adds up to 100%. Finally, certain POs are common for each CLO, thus satisfying those outcomes to a great extent.

Course Learning Objectives:

Objective 1: Apply the principles of Statics to determine the forces and moments on load carrying members. [ME POs a (35%), c (30%), e (30%), and i (5%)]

Objective 2: Analyze the stresses in load carrying members due to axial forces, bearing forces, torsional moments, bending moments and shear forces. [ME POs a (35%), c (30%), e (30%), and k (5%)]

Objective 3: Analyze the combined stresses in load carrying members due to axial forces, torsional moments, and bending moments acting together. [ME POs a (35%), c (25%), e (30%), and k (10%)]

Objective 4: Determine the deflection of load carrying, members due to axial loads, torsional moments and bending moments. [ME POs a (35%), c (30%), e (30%), and k (5%)]

Objective 5: Objective 5: Apply the principles learned from the objectives 1 through 4 to perform basic analysis and sizing of different structural members. [ME POs a (25%), c (25%), d (10%), e (25%), g (5%), i (5%), and k (5%)]

Evaluation and Assessment Tools Used

Many in-class and outside of the class activities have been attempted in order to maintain a contact with the students and in turn the students with the solid mechanics subject matter. Conventionally, students keep in touch with the instructor outside of the classroom in the form of office hours or tutor labs, and with the subject matter (either individually or with a group) in the form of reading assignments, homework, and preparation for the examinations. For many students, this set up is often not enough to prepare them well in order to achieve a satisfactory overall performance in a particular class. In some cases this set up can even lead to frustration among the young students who may not be able to ‘catch up’ with the pace of class material coverage. In that case, a situation can arise in which such students ‘give up’ or just try to barely pass a course. All this may be attributed to bad study habits; however, many students have tight term schedules and any outside classroom activity might help them in understanding material in a different way as kinesthetic learners. Some of the following pre-class, in-class and outside the class activities can be used as assessment tools of the students’ learning.

“Heads-up” or “Wake-up” e-mail communication

As mentioned before, in order to try to bridge the gap due to internship between two academic terms, the students who enrolled in the Mechanics (Solids) class were contacted via Blackboard. These students are still in their work term (or the 3-month internship) at the time when they were contacted. Solids course syllabus and Statics review material are the primary attachments to the e-mail sent to them. The idea of this “Wake up call” is that the students get an opportunity to purchase the Solids textbook early (possibly at a cheaper price) and also start to review the Statics material in a view to get better prepared to take the Statics competency test during the second week of the school term. Up on returning to the school, the students were asked to fill out a brief survey that consisted of the following questions:

- a) Did you receive my e-mail while you were at work? If not, why?
- b) Did you read and understand the contents of this e-mail?
- c) Do you think that this e-mail information is important to you? Why? Why not?
- d) Did you attempt to read the Statics review material that was e-mailed to you? Why? Why not?
- e) Has the Statics review material helped you to remember and to better understand the material covered when you took the Statics class?
- f) Did you attempt to solve or practice the sample questions e-mailed to you?
- g) Did you order the Solids textbook, and if so, did you get a chance to start reading the material? Why? Why not?

h) Are you well prepared now to take the Statics competency test?

The answers to this survey revealed that almost all students received, read and understood the contents of the e-mail sent. They all agreed that the intent of the e-mail alert was important to them at least to some extent. However, very few tried to order the Solids textbook while some of them answered that they reviewed the Statics material only briefly due to lack of time. Only a few students attempted to solve the sample test sent. Almost the entire class said that they must review the Statics material from now on in order to do well on the competency test to be given during the second week of classes, as well as to do well in the Solids class. The response seems to be discouraging as many students did not seem to fully realize the impact and deficiencies that a *gap* can create.

Statics Competency test

The second evaluation tool used was to give the *competency test* during the second week of classes. The first week was primarily spent in reviewing the important concepts of Statics such as equilibrium of 2D rigid bodies (including couples, trusses), center of gravity (composite bodies) and internal loads (bending moment and shear force calculations at a particular section). Two in-class activities covering the review material as mentioned above, one comprehensive take home, and one sample or practice exam have been assigned to get the students ready to take the Statics competency test. The competency (web-based) test designed by Steiff⁷ was administered for this. The actual test comprised of around 27 carefully designed multiple-choice questions. The test carried 3 to 5% of their final grade. The students were given a time period of 6 days to take this test. However, they have to finish the test in one sitting and in about one hour. The outcome of this test was that their performance was at an average level compared to other schools that use Steiff's test. One of the reasons for their average performance was due to lack of coverage of friction topic in Statics at Kettering University where as a few questions on the test were based on friction concept. The second main reason was due to the lack of preparation on the part of the students. This deficiency is being addressed to cover friction in Statics course.

Self-assessment Essay

Students are periodically asked to write a self-assessment essay outlining how they are performing in Solids class and to what extent, and if any, changes or suggestions might be warranted to improve their learning of the material. This is very helpful to the learner as well as to the instructor to take any just in time corrective actions for the rest of a term. Student expectations of a grade in the class will also become more realistic rather than based on pure anticipation.

Classwork versus Homework

From the author's experience, it was found that many students either copy the assigned homework from different sources or simply do many mistakes if working on their own. Many seldom use office hours due to many reasons, the main reason being their tight

schedule. It was therefore told to them that more weightage will be given to *in-class problems* thus making them to attend almost all classes. However, homework is still assigned for those wishing to make up any lost points on the classwork, but not for extra credit. They work in groups while doing the classwork. Some times, different but similar problems are assigned to a batch of groups. For example, groups 1, 5 and 7 located at different desks or tables inside the classroom work on the same problem while another set of 3 groups work on another similar problem.

All assigned problems are systematically formulated and solved by each group in a certain allocated time, following what was covered in the lecture. Students check their answers with other groups (solving the same problem) to check if all of them got the same answer. If not, they spend a little more time to find and correct any mistakes. This *cooperative learning* helped the students a lot in finding their own mistakes. Also the students were asked to come prepared to the class by doing the *reading assignments*. However, many do not come prepared and so majority tends to take more time to solve simple problems. As the classes progress during the term, many students became aware of their study habits and came better prepared for each class to some extent; thus they took less time to solve problems as a group, if not correctly all the time. Some times the students are asked to show only the methodology and steps for solving the problem. They were then asked to complete the solution as group *homework*. Some times the data in the same problems is changed for each group (for example the magnitude of a load or the angle of application of a load), so that their results can be plotted on the board as trend lines. Those who get wrong answers fall out of bounds of the trend line(s) and they immediately realize their mistakes. Careful design of classwork problems seems to help students to a great extent as they learn the problem solving techniques just in time. The feed back from the students seem to be very positive to this methodology.

Field problems

'Field problems' are the real life examples that the students are asked to pick on their own. Many field problems can be chosen without having to leave the campus. For example, a small fire extinguisher is an example of a simplified pressure cylinder. Although rigorous fire codes are needed to design those, a house hold or a dormitory fire extinguisher is an application of a thin or thick walled pressure cylinder concept. Another field problem based on this same concept is a propane gas cylinder that can be found in the backyard of student dormitories or at the fraternity or sorority houses. The goal of this exercise is that students will identify the known data (for example the maximum pressure, material and estimate what the thickness may be. Tall sign posts (for example, McDonald and such) are other examples to estimate the wind loads that can cause failure of the bolts used to fasten the post. Students seem to understand the concepts quickly, find it challenging to model the real life application (estimating the geometry, material and load) to solve for the unknown parameters. A few students choose project ideas from the mini-Baja or SAE Formula car team. Some of these ideas include performing simple FEA studies followed by verification by simple hand calculations. They find it challenging to set the appropriate boundary conditions and load conditions that a real life problem has.

Such outside class activities can be very rewarding in identifying real life applications of concepts learned while also enjoying the fun of being outdoors.

Classroom presentations

As is the case with many instructors, the author contributes to several technical societies and magazines such as Mechanical Engineering (ASME), Automotive Engineering (SAE), etc. One of the CLOs (or SLOs) of the Solids and Machine Design classes is to ask the students to read and discuss the latest articles and case studies in the mechanics and design areas. Therefore, the author distributed such magazines randomly to each student to read and to pick any topic of their interest to understand and to research further from other resources (internet, etc) if they were considering to present that topic to the class. They then are asked to present their topic for discussion to the class using power point slides that contain a list of references used. Such presentations were made optional to earn extra credit that compensates for any lost points on home work or class work. The student response to this activity has not been very encouraging in that only two to three persons each term chose to do such presentation. Those who volunteered, made the presentations not just to earn the extra credit, but because they seem to have genuine interest and have some knowledge in the chosen topic area from their co-op or their internship experience. Lack of time due to tight school term schedule may be one reason for poor participation from others in the class.

Speaker Presentations

In order to promote professionalism and to attempt to satisfy one of the ABET criteria of 'Continuous improvement', the students are provided with another opportunity (for extra credit) to attend technical speaker presentations. Most of these presentations (2 to 3 per term) are held on campus during lunch hours. These presentations are sponsored by the student chapters of ASME, SWE, etc., and also by honor societies such as Pi Tau Sigma. Students are also encouraged to join as members of such societies. The speakers are usually from outside, either from an industry or from an R&D institution. Some times the students arrange the speakers from their co-op industry. Extra credit was given based on whether they simply attend the seminar, or in addition, write a brief technical report of what was presented, and on how that topic relates to the themes of the class material. All students are provided with the ABET ('a' thru 'k' and 'l' to 'm') criteria so that when they write this report, they attempt to address which criteria is satisfied and to what extent in their view. In the author's view, the response to this activity has been by far overwhelming and the student reports of the speaker presentations have been very valuable in the assessment of their life-long learning criteria.

Mini-projects

Mini-projects are a little different than the field problems in that the mini-projects are assigned by the instructor and all students are required to attempt either individually or as a group. Each term, 2 or 3 mini-projects are assigned that are based on using a computational tool involving performing of design iterations, developing simple design

charts, and validations by hand calculations. Students are asked to write the learning experiences as a part of their report. The students' feedback on this activity has been very positive as many mentioned that mini-projects helped them in understanding the influence and sensitivity of the design parameters. Many also mentioned that mini-projects improved their problem solving ability.

Midterm and Common-hour Final Examinations

In addition to the above mentioned activities and assessment tools, midterm exams and a common-hour comprehensive final examination have been administered to assess the overall performance of the students. Although an assessment of each of the individual activities mentioned has been performed to some extent, in this paper, only the overall assessment of the students based on the final examination is presented. It is the author's belief that some of the in-class and outside class room activities influenced the students' performance on the final examination. Thus it is believed that the sample assessment charts presented at the end of the paper are a reasonable measure of mapping the POs with the CLOs for the Solids course at Kettering University.

A sample question from the common-hour finals is given below along with the CLOs and weights to which they are anticipated to satisfy.

Sample Final Examination Question

1. An electric motor drives the aluminum shaft $ABCD$ when it is rotating at a constant speed. Knowing that the torques exerted on pulleys B and C are as shown,
 - a. (CLO #1: 20%) draw the free body diagram of the entire shaft $ABCD$ to determine the torque delivered by the motor,
 - b. (CLO #1: 30%) draw the free body diagram of individual portions of the shaft (AB , BC , and CD) to determine the torque carried by each section of the shaft,
 - c. (CLO #2: 25%) determine the maximum torsional shearing stress in segments AB , BC , and CD of the shaft, and
 - d. (CLO #4: 25%) determine the angle of twist between B and C . Use $G = 27$ GPa.

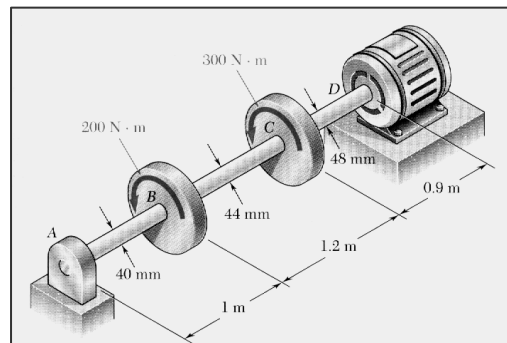

The sample charts shown in figures 1 through 7 are for the Winter 2007 class of around 83 students. Charts 1 to 3 depict the class understanding of ‘a through k’ and ‘1 to n’ ABET outcomes based on calculations from faculty provided data. Specifically faculty provided the Course Learning Objectives (CLOs) for the course as well as how the CLO’s related to the ABET outcomes and the questions. From this information the spreadsheet is able to calculate which ABET outcomes were covered on each question and to what extent. This information allows the program to make further calculations to determine how well students did on each individual outcome. This is what is shown in sample charts 1-3 for outcomes ‘a’, ‘c’ and ‘e’. These outcomes are capitalized for clarity on the charts. One can see from this that ABET outcome “a” has a weight of 34%. 34% of the final exam covered outcome “a”, and 42% of the time that question concerning outcome “a”, students had a grade of 93% or better. This information easily shows faculty what outcomes they are meeting their goals on and which may need further work for continuous improvement.

Figures 4 through 6 show a more streamlined set of assessment tools. Figure 4 gives a straight class average by question. This gives a quick snapshot for faculty to see what questions may be troubling students. Figure 5 shows the class average by CLO, again giving faculty a quick snapshot. Figure 6 shows the class average by ABET outcome. These three charts combined can show quickly where performance meets criteria, or where work needs to be done.

As mentioned before, there were 83 students in the class when this data was collected. The percentages were calculated based on a certain weightage formula. These charts show that more than around 75% of the time the concerned ABET outcomes have been satisfied with certain outcomes that need to be scrutinized for further modifications. Figure 4 shows the class averages for each question on the common hour final examination. This shows that the students did not perform well on question 2. An average performance of 70% or above was considered to be okay to satisfy that criteria. Question 2 was concerning the thermal stress in a stepped bar. Figure 7 shows students’ performance on the pre-test as evaluated by Steif’s program. Compared to the other schools who took his test, the current class average was reported to be just below the other school averages. This has been the case during the previous years when the author gave Steif’s test, which prompted the author to try different teaching tools as outlined in this paper. The students’ response has been very positive. Chart 8 shows the class averages by question for the Summer ’06 class of around 40 students. The questions were some what similar although not in the same order. Not all the tools described here were used in Summer ’06. The performance by the Winter 2007 students (per Chart 4) shows some improvement in the class averages by question.

Summary and Conclusions

This paper described several teaching and assessment tools used in the Solid Mechanics course taught at Kettering University. This course is introductory in nature and is a prerequisite to other classes. Some of the assessment tools are in the form of in-class

activities while others are meant to be for outside class activity. In the author's experience, the classwork provided some what just in time learning experience for many students while carefully designed homework, the competency examination, mini-projects, student presentations, and the midterm and final examinations serve as other tools for assessing the students' learning. Many of these activities are standard tools followed by many instructors and thus they reinforce the need for continuous improvement. Assessment of the common-hour final examination is presented in the form of charts and briefly discussed. Lessons learned from the assessment of these activities will be used for future classes.

Acknowledgements

The author wishes to acknowledge Ms. Erin Bolton, Administrative Assistant of the department of mechanical engineering at Kettering University for the development of the Excel spreadsheets and for providing the charts presented in this paper. Thanks are also due to the Mechanics faculty team for the efforts put in to help the author design the Solid Mechanics Course at Kettering University.

Bibliography

1. Krumsieg, K., and Baehr, M., "Foundations of Learning", 3rd Edition, published by Pacific Crest, Corvallis, OR, 2000.
2. Bowe, M., et al., "When Multimedia Doesn't Work: An Assessment of Visualization Modules for Learning Enhancement in Mechanics", Research Publication 3 Education Series published by Institute for Information and Technology Applications (IITA) at the USAF Academy. This paper was previously published by the American Society of Engineering Education at the annual conference in June 2000.
3. Nathan, R., "Integrating Multi-Media Aids (Tablet-Pc, Streaming Videos, and Electronic Slides) to the Fundamental Instruction in Mechanics", Proceedings of ASEE 2006 Conference held in Chicago.
4. Moe, G., "Using Interactive Assessment Tools in the Classroom", Proceedings of ASEE 2006 Conference held in Chicago.
5. Elahinia, M., and Ciocanel, C., "Redeveloping the Mechanics and Vibration Laboratory: A Problem Solving Approach", Proceedings of ASEE Conference held in Chicago.
6. Steif, P.S., and Dantzler, J.A., "A Statics Concept Inventory: Development and Psychometric Analysis", ASEE JEE, October 2005, pp. 363-371.
7. Steif, P.S., and Naples, L.M., "Design and Evaluation of Problem Solving Courseware Modules for Mechanics of Materials", ASEE JEE, July 2003, pp. 239-247.

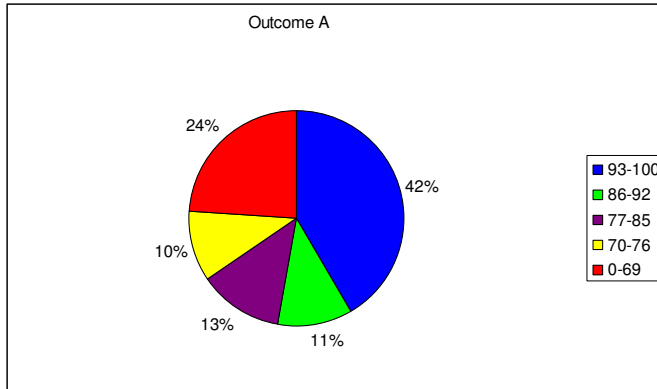

Figure 1: Outcome A – 34% weight

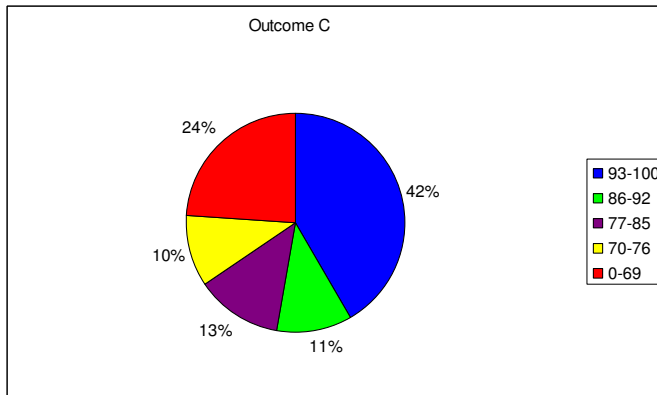

Figure 2: Outcome C – 30% weight

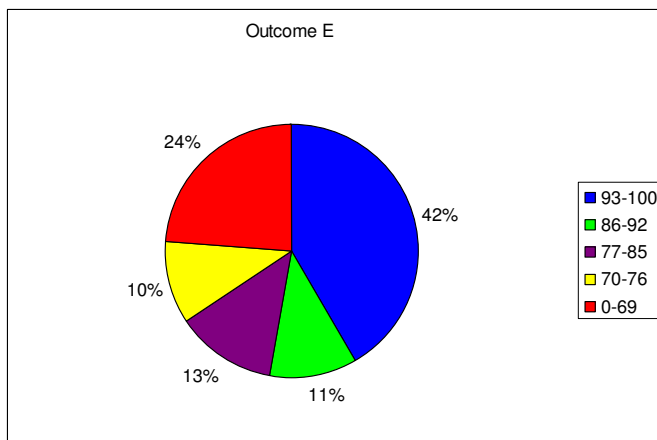

Figure 3: Outcome E – 30% weight

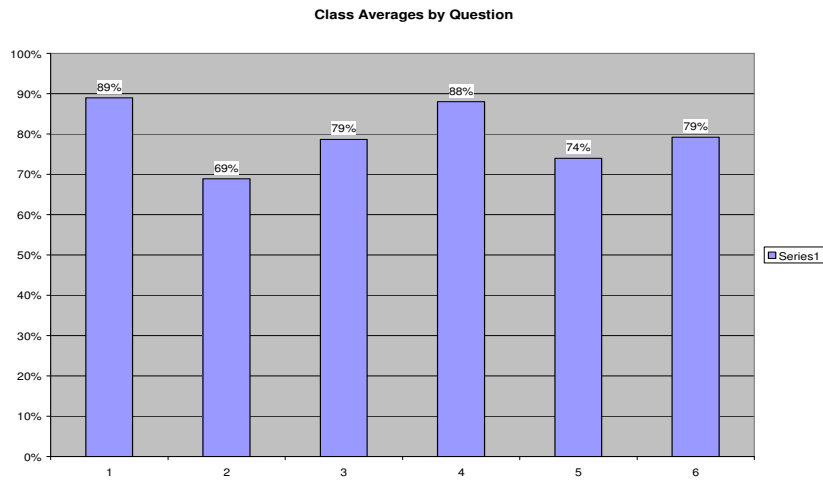

Figure 4: Class Averages by Question

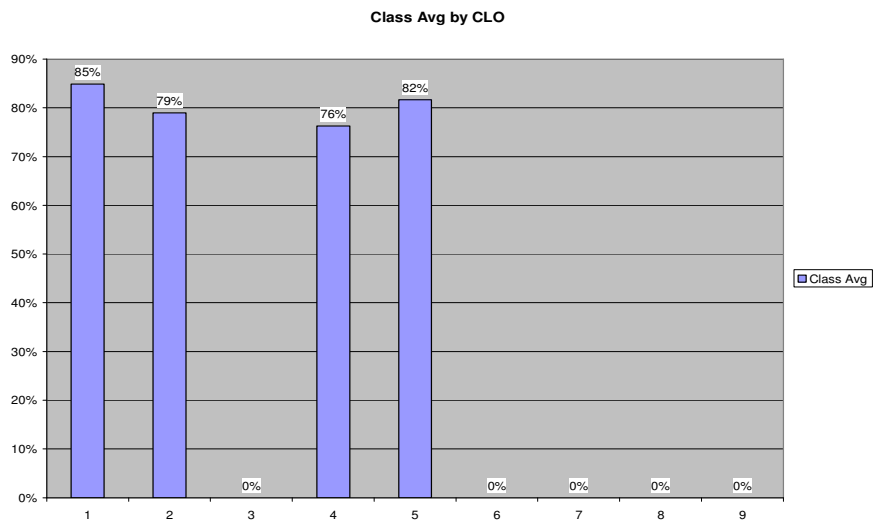

Figure 5: Class Averages by CLO

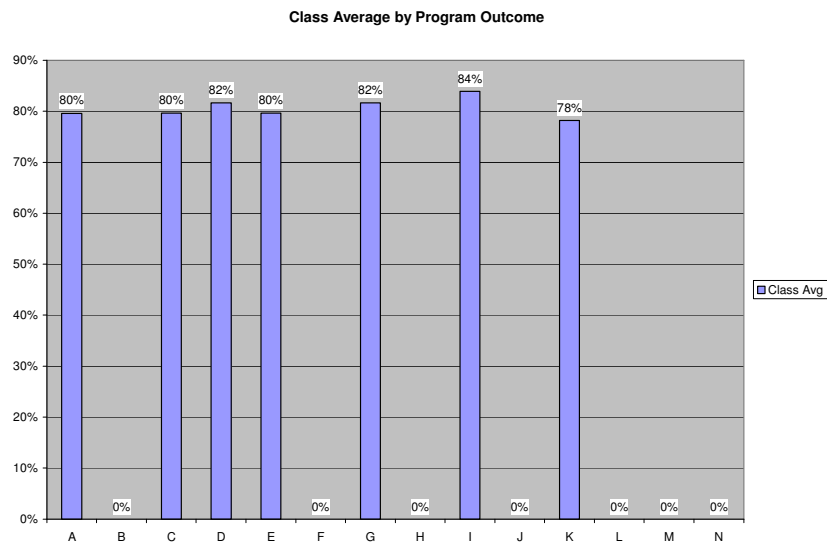

Figure 6: Class averages by Program Outcomes

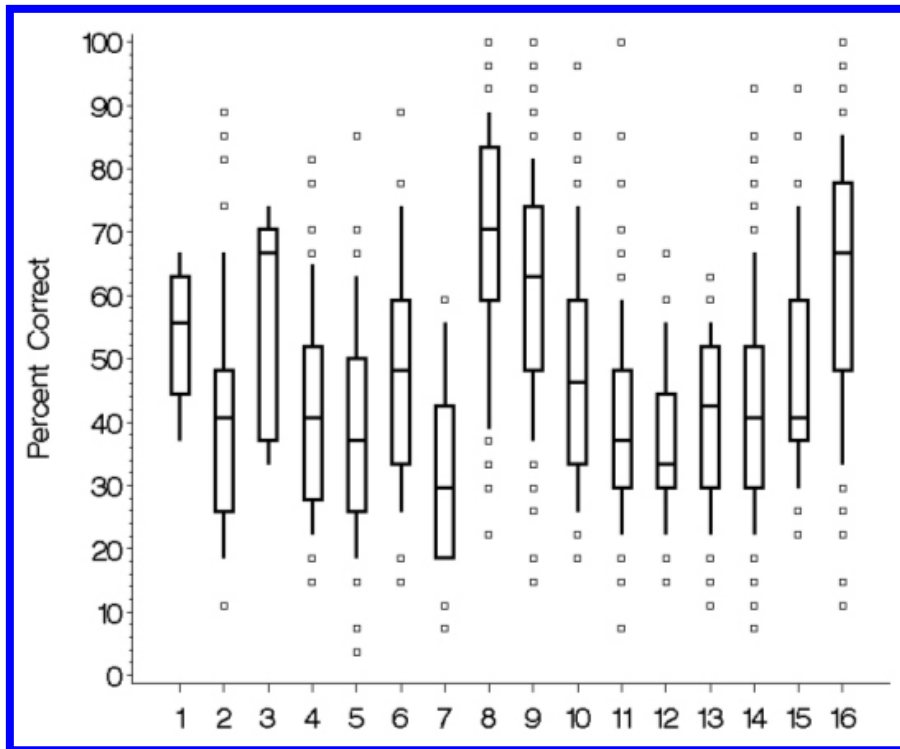

Figure 7: Class averages on Statics Competency Test (provided by Steif)

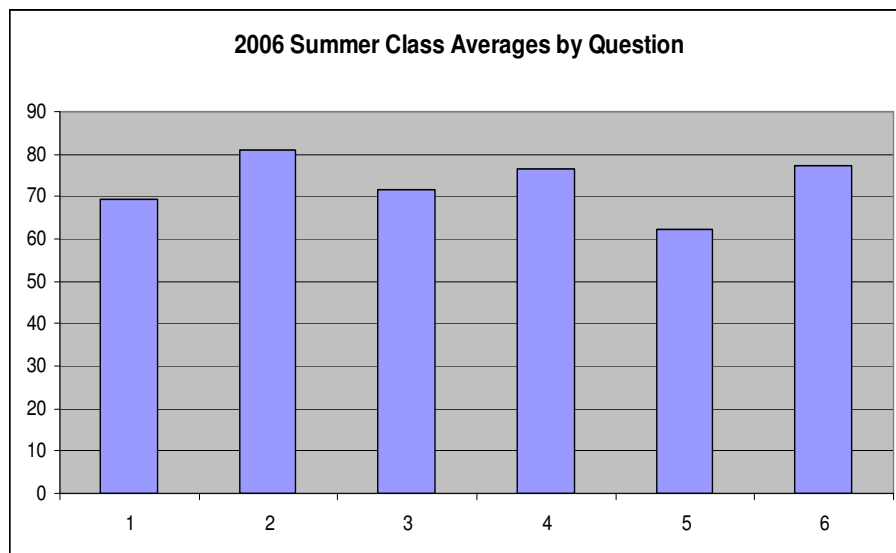

Figure 8: Class averages by Question (Summer 2006 class of 41 students)