

AC 2007-1178: "LESSONS WITH LUNCH" USING A COMMON TECHNOLOGY WITH A GLOBAL IMPACT TO ADDRESS TECHNOLOGY AND DATA LITERACY

Camille George, University of St. Thomas

Professor George, Ph.D., is an Assistant Professor in mechanical engineering at the University of St. Thomas. She teaches the core course in thermodynamics and maintains a strong interest in technology literacy and educating the general public. Professor George has prepared several innovative courses including a course specifically about fuel cells that mixed senior engineering students with students from other disciplines and adult learners (non-engineers). Professor George has also spearheaded several international service-learning projects in Haiti and Mali. These innovative projects included students from the department of Modern and Classical Languages, the communication studies department and the engineering program for an interdisciplinary year-long effort.

Elise Amel, University of Saint Thomas

Professor Amel, Ph.D., is trained as an industrial/organizational psychologist. Her most recent research, however, is in the area of conservation psychology, understanding people's reciprocal relationship to the rest of the natural world. Her expertise includes survey development, psychometrics (reliability, validity, utility), data analysis, as well as environmental and feminist issues in psychology. She is interested in how gender affects career choice. She believes strongly in the scientist-practitioner model, using her academic background to solve practical problems and using her problem solving experiences to enhance her teaching. She has received an award for excellence in service learning. Professor Amel has specific expertise developing assessment plans and dissemination approaches through her work on the UST Bush Foundation Grant. She has completed pedagogical presentations and publications about international education and service learning.

Christopher Greene, University of Saint Thomas

Dr. Chris Greene comes to the University of St. Thomas following a 20+ year career in industry. His experiences have included doing research in controlling aircraft and spacecraft and applied adaptive estimation to the detection of accidents on freeways and to navigation system development. He has worked for a variety of companies including Honeywell's Systems and Research Center and later their Avionics Division. Following a brief period at Diversified Technology Systems where he directed the development of automated semiconductor processing equipment, he went to work for Horton Inc (later know as Nexen Group Inc) where he became the Product Manager for all their industrial products.

His interests include applying PC-based control solutions to industrial control problems. He teaches various Electrical Engineering courses including Control Systems and Automation, Signals and Systems and Electronics.

“Lessons with Lunch”

Using a Common Technology with a Global Impact to Address Technology and Data Literacy

Abstract

Refrigeration has impacted our society in fundamental ways. In the developed world, our food security is dependent on fresh produce being transported over large distances in refrigerated containers. Chilled vaccines, antibiotics and organs for transplants illustrate the inseparable relationship between modern medical practice and refrigeration. Air-conditioning has altered our architecture. Refrigeration has influenced our military practices easing the burden of desert warfare. Our modern society could not function without refrigeration, yet few people either understand the technology behind refrigeration or examine its long-term sustainability. In general, few people discuss the additional amount of electricity that would have to be generated to simply provide this technology to the four billion people in the world who currently have no access to it or what resources would be used to provide this extra power. Few people reflect on the production and management issues of modern-day man-made refrigerants; a massive global expansion of devices containing toxic substances should be approached prudently. This paper describes two hands-on activities that elucidate this common and influential technology. Both activities can be used in a standard, undergraduate engineering laboratory or in a technology literacy course that fulfills the common science with lab requirement in a liberal arts program. In one activity, laboratory refrigeration trainers, instrumented with thermocouples and pressure gages, are connected to laptop computers programmed with a graphical interface. Easily understandable graphics enable the visualization of the 1st and 2nd laws of thermodynamics. The required work input, the relationship of energy transfer through phase-change and the principals of heat transfer all come alive by manipulating discrete data into visual representations of the system components. Each refrigeration trainer has a different style and shape of evaporator which permits many different foods to be chilled during the course of the laboratory. Lunch becomes the metaphor for the role of technology in meeting the world’s food and energy needs. To sensitize the students to the technical challenges and limitations of working with systems using toxic substances, students braze and then leak-test tubing connections in a second activity. The paper describes these engaging activities, presents the details behind the data manipulation software and presents a survey used to assess the learning and attitudes of a group of future science and math elementary teachers.

Introduction

Educators are increasingly aware of the importance of introducing contemporary and global issues in undergraduate curriculum. Liberal arts programs usually consider contemporary issues from many angles: social, political, ethical, organizational and personal. However, liberal arts courses rarely consider how engineering accomplishments affect society. One can argue that the average engineering major knows more about the humanities than the average humanities major knows about engineering. However, in our technology-driven society, everyone needs to know more about engineering, especially its limitations.¹ Many engineering advances have had an

enormous impact on our everyday lives. Thus, people need to know how engineering and public policy interact in our society, and have some expertise in judging engineering works.

Refrigeration is one such technology that has fundamentally and irreversibly changed the developed world. Refrigeration is for most Americans an invisible technology used by everyone every day. It has become a non-negotiable necessity. However, few engineers and even fewer non-engineers have considered its social, ethical and environmental implications. In its current form, refrigeration technology is not sustainable. Refrigeration requires substantial amounts of electricity and, in most commercial systems, works by changing the phase of a man-made toxic substance. More specifically, refrigeration is an *energy consuming technology* that depends on a reliable source of cheap electricity. At present there is not enough affordable power to export this technology globally. Also, release of refrigerants causes irreversible environmental damage. Fortunately, in the developed world the management of refrigerants is highly controlled. However, international law does not involve itself in industrial hazards, pollution or regulating multinational corporations. As a result refrigerant reclamation lacks international standards. It is not uncommon to see discarded air conditioners and refrigerators along roadsides in the developing world.

Most college age students have a vague idea that they should buy energy efficient appliances and should practice energy efficiency in their daily lives. They understand that our energy resources are limited, but few understand the methods and principles by which energy conversion devices operate or have considered the environmental and societal impacts of appliances in common use.

Citizens that understand the inherent limitations of our man made systems are in a better position to consider the policy implications governing energy production and use. A better educated citizenry, one that better understands that engineering is imperfect, will be better able to understand the influence of technology in the global marketplace and better assume the responsibilities of creating a sustainable and just world.

The activities described in this paper specifically consider refrigeration and can be used by the small but growing number of educators involved with providing energy education to help develop technology literacy for the non-engineering population.^{2,3} Technology literacy is thought to have three interdependent dimensions: “knowledge, capabilities, and ways of thinking and acting [critical thinking and decision making]”.⁴ It examines not just how a certain technology works but also how that technology interacts with “the people and infrastructure needed to design, manufacture, operate, and repair the artifacts”.⁴

Why Refrigeration and Technology Literacy?

Connection through impact

Refrigeration has fundamentally impacted our society. Men no longer harvest ice from New England or the upper Midwest (a multi-million dollar industry in the 19th century⁵). Women in the United States no longer spend large amounts of time canning, pickling and drying food between harvests.⁶ Our food security is currently dependent on fresh produce being transported over large distances in refrigerated containers. Refrigerated vaccines, donor organs, and

antibiotics have changed medical practice. Air-conditioning has altered our architecture and facilitated modern day migrations of people to hotter climates. Refrigeration has influenced our military practices enabling contemporary desert warfare. Refrigeration affects our food, shelter, health and national security. In short, our way of life depends on refrigeration. Without it our society would be in crisis. It is a technology “by which humans have modified nature to meet their wants and needs”.⁷

Explanation of physical laws

Many engineering students have difficulty understanding and connecting the fundamental relationships of thermodynamics and the physical behavior of real systems.⁸ Mathematical models seem abstract and counterintuitive. For the average person, refrigeration appears complex and beyond their comprehension. Also, most people have limited real world experience with the behavior and consequences of phase changes or with multiunit cyclic systems. However, refrigeration is an excellent example of how man has utilized the natural laws to create a technology for his own benefit.

The study of refrigeration can illustrate two fundamental principles, that energy is conserved and its transfer has a specific direction (1st and 2nd laws of thermodynamics). Thus, a working refrigerator is an excellent tool that can be used in a guided laboratory experience to demystify a real system and help build understanding of scientific phenomena. In a working refrigerator it is possible to trace the path of the refrigerant flow, identify from touch the hot and cold sides, as well as hear the unit’s functions, by turning the fans on and off and listening to the compressor. Temperature and power consumption can be measured and understood by almost everyone. Temperature values of a simple product such as a can of soda in a refrigerator can be plotted versus time to *physically see* heat being transferred. For more advanced students, pressure and volume can be plotted on property diagrams to see the work required per cycle, which can then be compared with actual measurements. Learners can make clear connections between the scientific and mathematical descriptions and the physical reality of the cyclic process in front of them. As a result, refrigeration is a very real and accessible way to introduce basic engineering concepts and terms.

Analysis of technology benefits and risks

For most people in the developed world refrigeration is considered a necessity and not a luxury. However, refrigeration never happens spontaneously. If one wants anything colder than ambient temperature it will take effort or work, and it will cost something. Refrigeration is a technology that benefits humankind but must be managed to minimize negative environmental impact. The history of refrigerants in the 20th century, and the unintended destruction of the ozone layer, gives a compelling example of how technology can adversely impact the environment.

Refrigerants are controlled substances. They are toxic and should not be released into the atmosphere. It is important to remind both engineering majors and non-majors that we must always dispose of our technology in an environmentally benign way. One implication is that, if we export our current technology to the developing world, we must take responsibility to safely harvest the refrigerants that at the end of each product’s lifetime. Refrigerator manufacturers and

distributors must be involved with pollution prevention and material recycling. A technologically literate person must understand and address the consequences of widespread improper disposal at a global level. At minimum, refrigeration must be designed to be leak-free during its lifetime but also easily retrievable at the end of its lifetime. Products such as automobile air conditioners should be made to be more robust so that ‘yearly charging’ is no longer an acceptable practice.

Refrigerators can be used to introduce construction materials and methods. Specifically, making a permanent and removable joint and performing a soap bubble test for leaks introduces the student to two different ways of combing tubing in order to make a closed, leak-proof system. The activity introduces trade vocabulary and demystifies simple construction techniques. Also, it helps to bridge the work of engineers and technicians. It is fun, easy, and for most students successful completion is empowering. Moreover, each student realizes that since technology is man made, it is fallible and must always be made to be as safe as possible.

Reflection on global energy inequities

We live in a culture where electricity is both reliable and inexpensive. In Minnesota, electricity costs \$.07/kW-hr and the small laboratory freezer described in the first hands-on activity would cost $\$.07/\text{kW-hr} * (0.17\text{kW}) * 24 \text{ hr} = \$0.29/\text{day}$ to run. In rural Mali (West Africa) electricity may cost $\$.31/\text{kW-hr}$.⁹ Thus, the same laboratory freezer would cost $\$.31/\text{kW-hr} * (0.17\text{kW}) * 24 \text{ hr} = \$1.26/\text{day}$. To provide context for this example, 59.2% of the population in Mali lives on about $\$1.00/\text{day}$.¹⁰ Most of the world’s rural poor, over a billion people, live on less than $\$4/\text{day}$.¹¹ A small refrigerator is simply unaffordable. One can then ask if the world’s current distribution of power is even morally acceptable. A calculation of the needed additional power capacity to supply every family with a refrigerator questions the very sustainability of the technology. We currently do not have the resources to supply this technology to everyone. Thus, wide-spread refrigeration becomes an issue of economic justice.

Using refrigeration as a case study for delivering technology literacy enables the student learning experience to include the broader context of social responsibility and global awareness. Students can thus be motivated to continue learning about new technologies such as alternative ways to generate energy, or alternative cooling strategies that could offer lower environmental hazards. A discussion of sustainable engineering should be at the very heart of technology literacy. Engineers will continue providing technologies and services to the global community but must do so with the objectives of resource efficiency and hazardous emission reduction.

Technology Literacy Activities

Two hands-on activities are presented that focus on the technology behind an everyday object, a refrigerator. The first activity emphasizes the function and operation of basic refrigeration and includes a discussion on how refrigeration has influenced our society. Specialized vocabulary is introduced and clearly defined making it less intimidating. Every effort is made to present a complicated artifact in a non-complicated way. The goal of the activity is to present engineering principles visually and physically. Mathematical descriptions are avoided because many non-engineers fear both science and math. The second activity attempts to build technology confidence by concentrating on how things are built. It also highlights the limitations of

technology. By introducing a pre- and post survey, students were asked to reflect on their opinion of engineering which can ultimately break down stereotypes as the technical world becomes more comprehensible.

1. Understanding how a refrigerator works

Lecture

Refrigerators move heat from one place to another. Heat always travels from hot to cold, and never the other way around. A short lecture is provided that introduces the 1st law of thermodynamics: energy is conserved. Energy can be transferred from one place to another through heat transfer, electricity, and mechanical work. It can be stored, but it cannot be created or destroyed. The lecture continues with the 2nd law, some events happen spontaneously, and in particular gas will always flow from high pressure to low pressure and never the other way around.

Materials can exist in different phases; gas, liquid or solid. A material's phase depends on the pressure or temperature and the local volume per unit mass. A refrigerator uses a fluid that can exist in two phases (gas and liquid) at accessible conditions. The heat is stored in weak intermolecular forces. Moving heat into or out of a two-phase fluid doesn't change the temperature but the order and disorder of the fluid, which can be viewed as a measure of entropy.

A heat exchanger in a refrigerator contains a two-phase fluid that can evaporate (boil) or can condense. It can easily absorb heat and become more and more vapor, or it can easily release heat and become more and more liquid. A refrigerator needs two of these, one colder than the food we want to chill, and one hotter than the space to which we transfer the heat.

A refrigerator takes heat from the food (or space) one wants to cool and transfers it to a colder place. Thus the food/interior box is always hotter than the evaporator (the interior heat exchanger). It is then necessary to move the heat some place else, thus the condenser (the exterior heat exchanger) must be hotter than the place to which you are transferring the heat (your kitchen or the exterior of a building).

To move the refrigerant in a closed loop, we supply electrical energy to compress the vapor physically or mechanically. The resulting high pressure fluid will want to spontaneously move to a lower pressure location. A restriction is put into the system at the end of the condenser where the refrigerant is in the liquid phase and is no longer releasing heat easily. The liquid refrigerant is then metered back to the low pressure evaporator. The cycle begins anew. The net result is the transfer of heat from one location to another. The net cost to the consumer is the electricity necessary to drive the compressor as well as the electricity used to power the auxiliary fans which facilitate more effective heat transfer. At this point the lecture can begin to explain how electricity is generated.

Demo

Materials

Instrumented freezer or refrigerator¹²
Thermocouples
USB- based 8-channel thermocouple input module
Laptop computer with LabVIEW
Pressure manifold
Food
Pop
Kill-a-watt meter to measure power

Activity

The main activity is to measure the temperature of the food over time. Thermocouples are attached to room temperature beverages and food. The edible items are placed in the refrigerators to observe the transient effects of heat transfer as the heat is moved from the items to the ambient room. The temperatures in the system are visually displayed using the system software. A combination of cartoons and numbers are presented to make the data acquisition fun and accessible. The collected data can be exported to an excel spreadsheet for more advanced student assignments. To provide tactile evidence, the students are encouraged to touch the temperature differences on a working unit.

Another feature is that students will monitor power usage using a kill-a-watt meter. The compressor and the fans are wired so that their relative power consumption can be isolated and measured. Additionally, compressor cycling can be observed when the fans are enabled and disabled, allowing the students to see the differences. At the end of the laboratory session, everyone eats lunch together.

2. Limitations of technology

Lecture

To build a closed system one needs to join tubing and devices together. There are two ways one can join copper tubing or connect tubing to a device. A non-permanent connection is made by flaring the end of the tubing and using a threaded nut. Soldering and brazing are both techniques that use filler materials to permanently bind two pieces of tubing. Low pressure systems, such as common plumbing systems, use lead as the filler material. Systems that encounter high pressures, like air conditioning and refrigeration, use brazing, sometimes called hard soldering. Brazing is done at very high temperatures and uses silver for the bonding filler. Copper tubing is available as soft copper or hard-drawn copper tubing. Soft copper can be bent whereas hard-drawn tubing is not intended to be bent. ACR (air conditioning and refrigeration) tubing is very clean and free of contamination. When purchased it is filled with nitrogen and capped. It is generally referred to by its OD, and the inner diameter is 1/8 inch less. Copper tubing in the US is available in diameters from 3/16 in to 6 in.¹³ A refrigeration system is a closed system and

must be kept leak free. The second hands-on activity allows the students to join tubing and leak test their connections. Details of the activity are presented in the Appendix A.

Understanding data manipulation

Understanding the data and its significance is an important aspect of the first activity. Every effort has been made to help the student visualize and understand how the technology works. “A picture is worth a 1000 words” especially applies to this application, thus it was desired to use a clear *visual* representation of the measured data and National Instrument’s LabVIEW was selected to display the information. By graphically showing the resulting data, students are more able to internalize both the cause-effect nature of the experiment and the overall lessons.

Using LabVIEW’s graphical interface has several advantages in this application.

Graphical Correlation of the Physical with its Representation

One challenge of experiments such as this is that it is frequently difficult for non-majors to see the relationship between a characteristic of a physical piece of equipment such as the temperature of the compressor and a traditional engineering reading. For example it can be difficult to keep track of the locations of all the thermocouples in our apparatus. By including a graphical representation on the control panel it makes the measurements more concrete and helps the student correlate the measurements with the hardware. Figure 1 shows the LabVIEW front panel created by some of our students to graphically depict, in real-time, the temperatures in the various sections of the refrigeration cycle. Future advances will include real-time measurement of key pressures and electrical energy inputs.

Real-Time Plotting of Data

The time frame of these experiments ranges from tens of minutes to an hour. As such, traditional data gathering approaches in which student’s record data manually provide a significant delay between a control action and being able to see its full effect, for example, as a graph. LabVIEW permits Real-Time data gathering and plotting. Thus it is possible to see the effect of an action as soon as a variable starts to change. This instant feedback emphasizes the connection between the cause and the effect of a change.

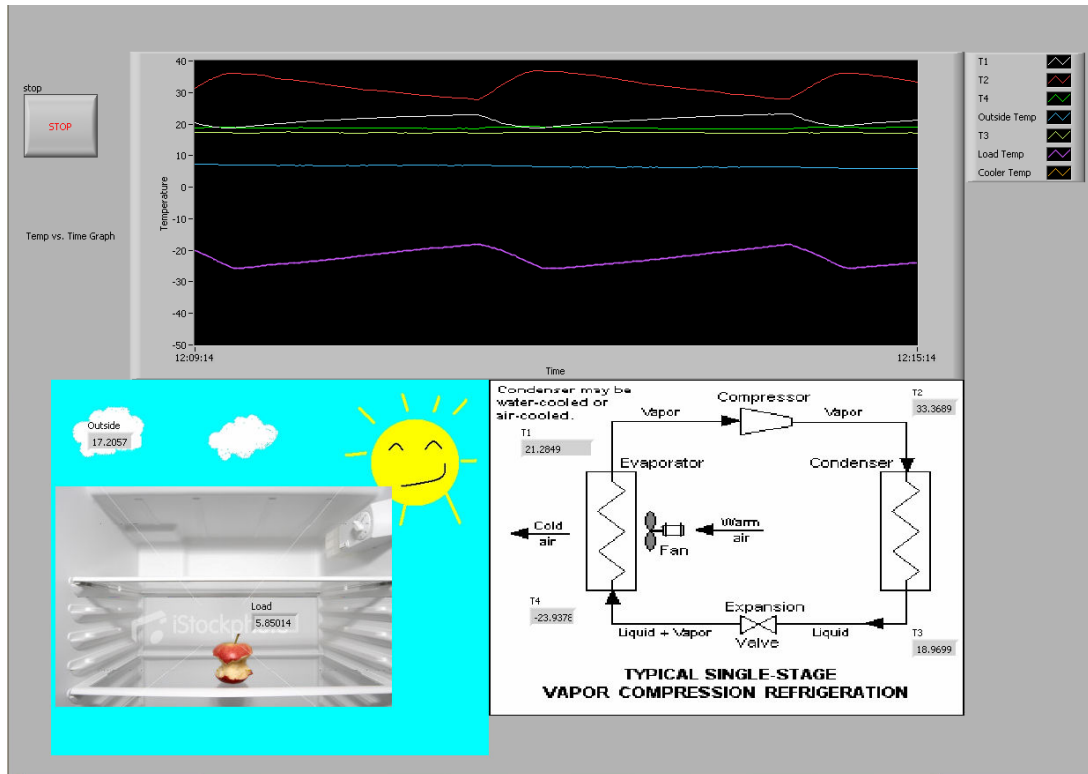

Figure 1 - Real-time Display of Temperatures at Various Points in the Refrigeration Cycle

Easy to Modify

Advanced students can modify the program, shown in Figure 2, and thus increase their interaction with the data. This results in their 'owning' the data and helps them to see the connection between the mathematical theory and the practical results.

These add up to a system that helps students see the connections between the data they are taking and its meaning. They also can see and modify the visual representations of the data to better interpret the information and to draw conclusions supported by that data. Taken together, this has the potential to help the student develop stronger critical thinking skills and to test hypotheses against data in meaningful ways.

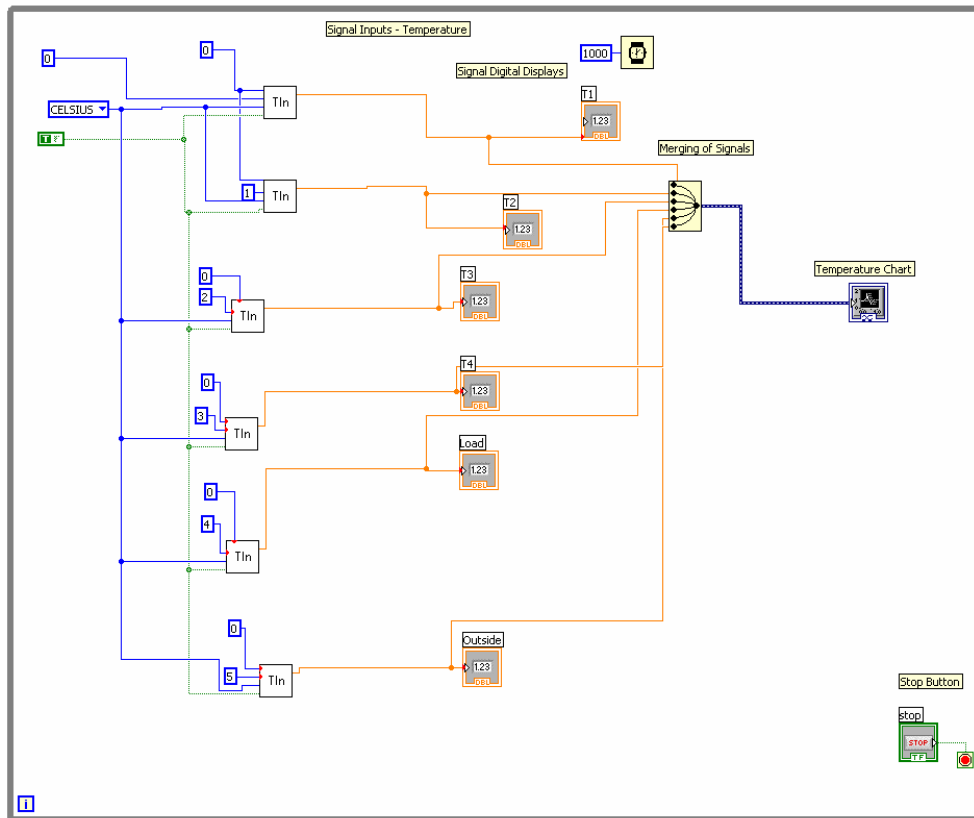

Figure 2 - LabVIEW Diagram Created by Students to Display Temperatures

Assessment of Activities

We collected data both before (see Appendix B) and after the workshop (see Appendix C) to note any changes in attitude and knowledge for the five non-science, elementary education majors who participated. We asked six attitudinal questions ranging in focus from broad (attitude toward engineering and technology) to narrow (freezer and pipe manipulation).

Results were mixed for the general questions but clearly positive for the specific phenomena covered in the workshop. Specifically, students did not perceive any difference in their confidence regarding science in general. Two found technology to be more understandable and one found it to be more confusing as a result of the workshop. Three students thought engineering was easier after the workshop, while two didn't change their estimate.

In contrast, all five students agreed or strongly agreed that they enjoyed studying the freezer. Many indicated that working with the freezer increased (3 students) or maintained (2 students) their interest in engineering. And, most indicated that soldering and brazing the piping increased (4 students) or maintained (1 student) their interest in engineering.

In order to measure any learning occurring due to the workshop, students were asked to describe the First and Second Laws of Thermodynamics. None correctly defined the First Law before the

workshop (4 didn't even try). However, all five correctly defined it after the workshop. Regarding pretest definitions of the Second Law of Thermodynamics, one student responded with a partially correct description of the Second Law before the workshop saying, "maybe having to do with heat produced" (4 didn't even try). Again, all five correctly defined the Second Law after the workshop.

Additional questions indicated that 4 students found it easier to understand *condensers*, *compressors*, and *soldering* equipment after the workshop (1 unchanged). Three students found it easier to understand *evaporators* after the workshop (2 unchanged).

Students also responded to some open ended questions about the workshop. In response to the *Most important concept learned from the freezer demo*, students indicated evaporators, cycles, and tubing size and connections. Cycles were mentioned again when asked about the *Most challenging part of understanding the freezer*. Participants indicated that the diagram, model and hands-on activities were *The part of the freezer workshop that taught [them] the most*.

When asked *How the freezer workshop has affected how or what you will teach*, students indicated that they would use the content (refrigeration and engineering) and the format (hands-on activities) learned in the workshop.

Conclusion

Two hands-on laboratory activities that can be used to introduce technology literacy are presented. The activities were presented to a group of non-major students. A follow-up survey measured increased awareness of energy issues and an increased interest in technology topics.

Acknowledgements

The research underlying this curriculum was supported by the National Science Foundation under grant # ESI-0341897. The authors would like to thank James Pechacek, Nicole Jackson, Peter Rhode, Karl Mueller and Vern Cottles for their invaluable help in making the activities come alive.

Bibliography

¹ National Academy of Engineering (NAE). 2002. *Technically Speaking: Why all Americans need to know more about technology*. Washington, DC: National Academy Press.

² Pisupati, S. V., Mathews, J. P., and Scaroni, A. W., *Energy Conservation Education for Non-Engineering Students and the Effectiveness of Active Learning Components*. 2003, Proceedings of the American Society of Engineering Education Annual Conference, Session 2533.

³ Krohn, J. L., and Apple, S. C., *Energy and the Environment: An Energy Education Course for High School Teachers*. 2003, Proceedings of the American Society of Engineering Education Annual Conference, Session 2533.

⁴ Ollis, D. and Pearson, G., *What is Technological Literacy and Why Does it Matter?* 2006. Proceedings of the American Society of Engineering Education Annual Conference, 2006-695.

⁵ Weightmann, Gavin (2003). *The Frozen Water Trade* pp. 105-111.

⁶ Wilder, Laura Ingalls (1940). *A Long Winter* pp.27-31.

⁷ NAE and NRC (National Academy of Engineering and National Research Council). 2002. *Technically Speaking: Why All Americans Need to Know More About Technology*. Washington, D.C.: National Academic Press.

⁸ O'Connell, J. P. and Scot, T.C., *Workshop Exercises for Connecting Fundamentals to Equipment in the First Thermodynamics Course*. 200?. Proceedings of the American Society of Engineering Education Annual Conference, Session 2333.

⁹ Personal correspondence with Afrilinks Mali.

¹⁰ <http://www.ruralpovertyportal.org/english/regions/africa/mli/index.htm>

¹¹ <http://www.un.org/millenniumgoals/>

¹² <http://courseweb.stthomas.edu/powerup/refrigeration/index.htm>

¹³ Chapter 7 Tubing and Piping in Refrigeration & Air Conditioning Technology 3rd Edition by Whitman & Johnson. ISBN 0-8273-5646-3.

Appendix A

Solder/brazing Activity

Materials

¼" Copper tubing

Flare nuts

Solder

Syl fos –dynaflo (silvabraze)

Paste flux

Liquid soap



Tools

Eye protection

Propane canister and torch tip

Mapp gas canister and its torch tip

Flame starter (if necessary)

45 ° Flaring block

Flaring yoke

Tube cutter

¼" Swaging punch

hammer, pliers

flux brush

heat proof pad

vice

Cutting & De-burring

Unroll the copper from the roll and avoid kinking it or bending it more than necessary. Cut the tubing with a tube cutter. Place the tubing onto the cutting wheel. Tighten the adjusting screw until a moderate pressure is applied. Revolve the cutter around the tubing keeping a moderate pressure. Adjust the screw after each turn around. Continue until the tube is cut. Each student should cut a 10 inch piece in two places so that each student has three pieces of about 3 inches each. De-burr the tube with the burr attachment on the cutter.

Tube bending

Always try to bend tubing with as large a radius as possible. Tube springs or a lever-type tube bender can be used. Point out to the students that tube benders have different radii, and to fit the tubing into the correct slot.

Making a flare joint

Flare joints are used when a component has a threaded connection. It is a removable joint. The objective is to make a flare angle on the end of the tubing that matches with the flare angle in a corresponding flare nut. It is a copper-to-copper fitting. Teflon tape or leak-lock is not used.

Slip the flare nut over the tubing with the threaded end facing the end of the tubing. Clamp the tube in the flaring block so that it sticks up about the thickness of a quarter. Place the yoke on the block with the tapered cone over the tube end. Turn the screw down firmly, release a bit, and continue screwing down until the flare is completed. Remove the tubing and visually inspect it. If it is ripped or has defects, cut it off and try again.

Making a swage joint

Swaging joins two pieces of the same diameter tubing permanently. One side is expanded to fit over the other so that the joint can be soldered or brazed. Place the tube in the flare block so that the tube extends above the block by an equal amount to the outer diameter plus a little. Insert the swage punch or a lever type swaging tool. Strike the punch with a hammer until the proper shape and joint length is achieved. Assemble the joint, the tubing should fit easily.

Soldering and Brazing

Both processes join tubing permanently. Soldering is done at lower temperature (less than 800°F) and uses 50/50 tin-lead as material filler and brazing (sometimes called silver-brazing, or hard solder) requires temperatures over 800°F, and uses a 95/5 silver mix as the filler metal. The idea behind both techniques is to heat the tubing enough so that the molten metal is drawn into the close-fitting space by capillary attraction. Soldering and brazing need different heat sources. For this activity, a propane cylinder and torch tip is used for soldering and mapp gas with its specific tip is used for the brazing. In the field most ACR tubing is brazed with an air-acetylene torch.

Soldering

Clean mating parts with an emery cloth or a wire brush. The two mating ends must be absolutely clean. Do not use sandpaper because the particles may contaminate your tubing. Apply a flux to the male connection. The flux minimizes oxidation during heating. Flux often comes as a paste. Apply it with a clean applicator brush. Assemble the tubing. Heat the joint. This is done slightly away from the seam. Heat the tube near the fitting. It is best to put the hottest part of the flame onto swaged area. You can move the flame around to ensure uniform heating. The flux should begin to burn off and during the burn-off apply the solder. Move the flame away with one hand and apply the solder with your second hand. If the solder doesn't readily melt, continue heating. Do not melt the solder with the flame. Don't over heat the tubing, otherwise the solder just beads off and doesn't get pulled into the space. The solder should flow freely into the space between the tubes.



Brazing

Clean the tubing in the same way as for soldering. Do not apply any flux. Assemble the tubing and apply heat to the joint until the joint is cherry red. Move the flame to ensure uniform heating. Apply the silver rod to the red-hot seam. The metal should flow easily into the space between the two tubes. Do not heat the silver itself; the joint should be hot enough to melt the filler metal. In a real application nitrogen is forced through the tubing to avoid oxidation.

Leak test

Remove the tubing from the vice with pliers and quench it in water to cool it down. Connect the flare fitting to a laboratory air line. Apply soap bubbles to check for leaks.

Appendix B

ID # _____

Please take a few minutes to complete this survey.

Please list 5 adjectives you would use to describe an engineer.

For the following questions, please mark the scale with a checkmark or an X.

1. Engineering is

easy : _____ : _____ : _____ : _____ : _____ : _____ : _____ : difficult

2. Technology is

confusing : _____ : _____ : _____ : _____ : _____ : _____ : _____ : understandable

3. I am confident in my science abilities.

strongly agree : _____ : _____ : _____ : _____ : _____ : _____ : _____ : strongly disagree

4. Please describe the First Law of Thermodynamics.

5. Please describe the Second Law of Thermodynamics.

6. Please rate the following equipment and processes:

	very easy to understand, use, or do	somewhat easy to understand, use, or do	unsure	somewhat frustrating to understand, use, or do	very frustrating to understand, use, or do
refrigeration cycle					
condenser					
evaporator					
compressor					
soldering tool					

Appendix C

ID # _____

Please take a few minutes to complete this survey about the SMEE workshop. The questions are specifically based on your experience with the freezer.

Please list 5 adjectives you would use to describe an engineer.

For the following questions, please mark the scale with a checkmark or an X.

1. Engineering is

easy : _____ : _____ : _____ : _____ : _____ : _____ : difficult

2. Technology is

confusing : _____ : _____ : _____ : _____ : _____ : _____ : understandable

3. I am confident in my science abilities.

strongly agree : _____ : _____ : _____ : _____ : _____ : _____ : strongly disagree

4. I enjoyed studying the freezer.

strongly agree : _____ : _____ : _____ : _____ : _____ : _____ : strongly disagree

5. Please describe the First Law of Thermodynamics.

6. Please describe the Second Law of Thermodynamics.

7. What was the most important concept you learned from the freezer demonstration?

8. What was the most challenging part of understanding the freezer?

9. What part of the freezer workshop taught you the most?

10. Please rate the following equipment and processes:

	very easy to understand, use, or do	somewhat easy to understand, use, or do	unsure	somewhat frustrating to understand, use, or do	very frustrating to understand, use, or do
refrigeration cycle					
condenser					
evaporator					
compressor					
soldering tool					
lectures					
other:					

11. Working with the freezer has INCREASED/MAINTAINED/DECREASED my interest in engineering.

12. Connecting the piping has INCREASED/MAINTAINED/DECREASED my interest in engineering.

13. Please indicate if/how the freezer workshop has affected how or what you will teach your students.

What suggestions do you have for improving the freezer workshop?

Other comments: