

**AC 2007-1587: PROJECT-BASED LEARNING USING TABLET PCS: A PRACTICE TO ENHANCE DESIGN COMPONENTS IN ENGINEERING INSTRUCTION**

**Jianyu Dong, California State University-Los Angeles**

**Nancy Warter-Perez, California State University-Los Angeles**

# **Project Based Learning Using Tablet PCs: A Practice to Enhance Design Components in Engineering Instruction**

## **Abstract**

This paper presents a Collaborative Project Based Learning model using Tablet PCs to enhance the design components in engineering classroom instruction. The core of our proposed model is to incorporate small in-class Tablet PC-based collaborative design projects to reinforce theory with design examples and to guide students through the design process. This PBL model has been implemented in three core computer engineering courses (Microcontroller Programming, Computer Logic Design, and Multimedia Networking) since Fall 2005 and the students' feedback has been very positive. In all pilot classes that incorporated the model, a significant improvement of students' hands-on skills was observed. The broad implementation of the model demonstrates that it could be applied to any course where computer aided or assisted design is an essential component. Course level assessment results will be included to show the impact on teaching efficiency and student learning outcomes. In addition, potential problems and implementation challenges will be discussed for future improvement.

## **Introduction**

The ability to design a system or a component to meet practical requirements is one of the essential skills that students should acquire through engineering education<sup>1-2</sup>. To enhance the students' design skills, many engineering educators have proposed various approaches, one of which is Project Based Learning (PBL)<sup>3</sup>. PBL has been recognized as an effective way to reinforce course theory and to improve students' hands-on skills. However, how to incorporate PBL into the curriculum remains an open question. This is particularly challenging on a commuter campus with a 10-week quarter and no teaching assistants, where students are often not on campus outside of class hours, there are no TAs for recitation sessions, and there is a short learning window especially for projects.

In years 2005 and 2006, California State University, Los Angeles (CSULA) received an HP teaching initiative award and subsequently an HP leadership award, which allowed us to explore a novel in-class Collaborative Project Based Learning model (CPBL) using Tablet PCs. The HP awards include three faculty stations and 60 Tablet PCs for students to use in the classroom. This equipment, along with the enabled wireless network, can easily transform a traditional classroom into a mobile computer room, which provides an ideal platform for collaborative learning. The core of our proposed CPBL model is to incorporate small in-class Tablet PC-based collaborative projects to stimulate students' interest in learning new theory, to reinforce theory with design examples, and to guide students through the design process. Dynamic presentations using Tablet PCs improve the efficiency of course material delivery. Thus, more interactive demos and hands-on design components can be accommodated within the same amount of instruction time.

This paper presents the details of the proposed CPBL model, as well as its implementation in three core computer engineering courses (Microcomputer Programming, Computer Logic Design, and Multimedia Networking). In the pilot classes that incorporated the proposed model, a significant improvement of students' hands-on skills was observed. The broad implementation

of the model demonstrates that it could be applied to any course where computer aided or assisted design is an essential component. Course level assessment results will be presented to show the impact on student learning outcomes. In addition, potential problems and implementation challenges will be discussed for future improvement.

## **Related Works**

As an emerging mobile computing device, the Tablet PC has attracted a significant amount of interest from researchers and educators. The ink-over feature of the Tablet PC allows an instructor to work on prepared slides in class, which combines the benefits of both PowerPoint and the blackboard presentations. In recent years, a number of presentation software tools (e.g. Class Presenter, Ubiquitous presenter, DyKnow's Software, etc.) have been developed to provide an integrated Tablet PC-based instruction environment that supports dynamic presentation, real-time polling, on-line coursework submission, etc. B. Simon, et al, have presented their work on using Class Presenter and Ubiquitous presenter in engineering classrooms<sup>4-5</sup>. V. Diaz, et al, have presented how to use DyKnow's Software to improve teaching efficiency in large classes through active learning, practice, and faculty engagement<sup>6</sup>. Tront introduced an enhanced software tool WriteOn to allow dynamic broadcasting of the computer screen with real time electronic ink and synchronized audio<sup>7</sup>. Most literature reported increased student engagement and more efficient course material delivery as a result of Tablet PC usage. In 2006, Lord and Perry presented their comparison results of several different presentation approaches in engineering classrooms, and concluded that the Tablet PC, although not a substitute for effective teaching, can be a useful tool to improve teaching effectiveness<sup>8</sup>. In general, the Tablet PC, as an efficient presentation platform, has been widely recognized.

Tablet PCs can be used for more than a tool for presentation or note-taking. Its interactive feature, unique human-computer interface, and high degree of mobility can easily support various types of active learning components in class. Also, Tablet PCs have been shown to be natural tools for engineering design where the tablet mode with pen can be used to sketch the design and the PC mode can be used for implementing the design and running simulations. Some engineering educators have reported their pilot work on design-oriented learning<sup>9</sup> and problem-based learning<sup>10</sup> using Tablet PCs.

Since Fall 2005, we have been working on the development of Tablet PC-based CPBL in classroom instruction. Some preliminary results have been reported<sup>11</sup>. This paper describes our extended work including implementation experiences and assessment results. We hope our experience can benefit our colleagues in teaching design components in engineering classroom.

## **Collaborative Project Based Learning (CPBL)**

As mentioned above, Project Based Learning (PBL) is an effective way to prepare students for the industry design process. Traditionally, PBL at CSULA has been implemented as follows. During the lectures, the instructor models the design process for the students and then the students apply the process in their project assignment after class. However, in this case, the feedback loop is not immediate to either the instructor presenting the material or the student trying to apply the concepts. The desire for an efficient and effective way to teach design

components motivated us to propose an in class PBL model which progressively trains the students using small collaborative in-class projects.

Figure 1(a) illustrates the setting of our proposed Collaborative Project Based Learning (CPBL) model. Students are divided into groups to work on assigned projects in class, e.g. the design of a register file in Computer Logic Design class (EE347), as shown in Figure 1(b). Usually, a collaborative effort is required to complete the project. Therefore, the students need to interact with each other within the group. It has been shown that a high degree of interaction among peers can make students more engaged in the learning process. In addition, the instructor will interact with every group to provide guidance in the design process, answer students' questions, and address any observed problems. The design results or problem solutions of each group can be easily demonstrated to the entire class using networked Tablet PCs.

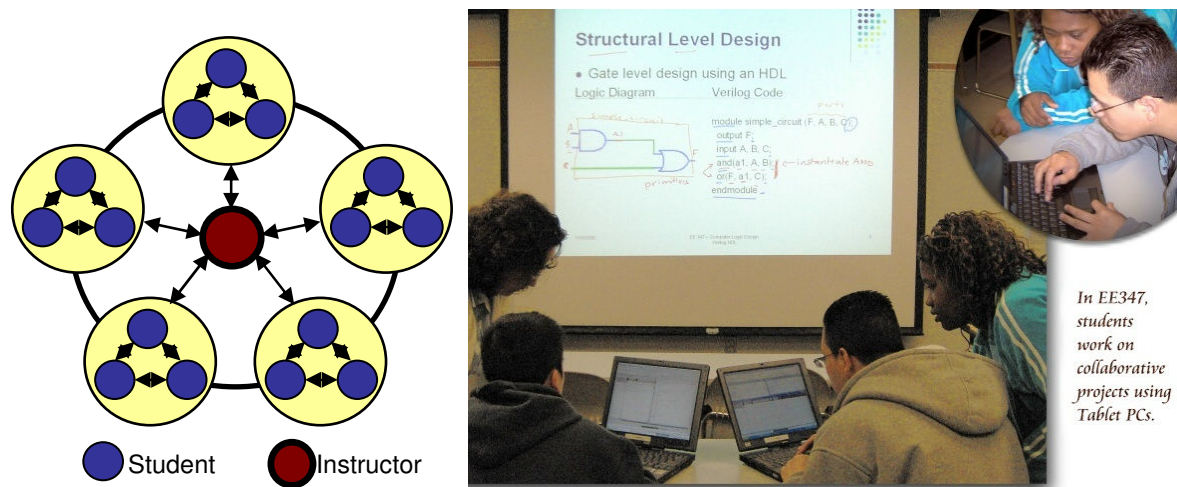

Figure 1. Collaborative design project: (a) Illustration of classroom setting and interaction model; b) A glance of students working together on design project in EE347 class.

The key component of the CPBL model is a set of well-designed small projects to build the students' knowledge and design skills step-by-step. Since adding in-class projects takes away from instruction time, it is important to create simple well-defined projects that can teach students about a new concept/process but not consume too much class time. Based on the objective of the in-class projects, they can be classified into the following two categories:

### 1) *Practical Projects to Build Design skills*

This type of projects is usually based on real world industrial projects. The goal is a working engineering product/design. For example, in EE442 (Multimedia Networking), the students are required to design and implement a real-time online VCR that is capable of transmitting video from one computer to another. Complex as it is, it can be doable when broken down into a set of small projects. Figure 2 illustrates the hierarchical structure of this type of project. At the beginning, the students will design simple and basic units in the system. Then, they will use these units to create more complicated parts in the system. To emulate the

industrial design process, each student in a group plays a different role. At the final stage, they will work together to integrate and test the entire system.

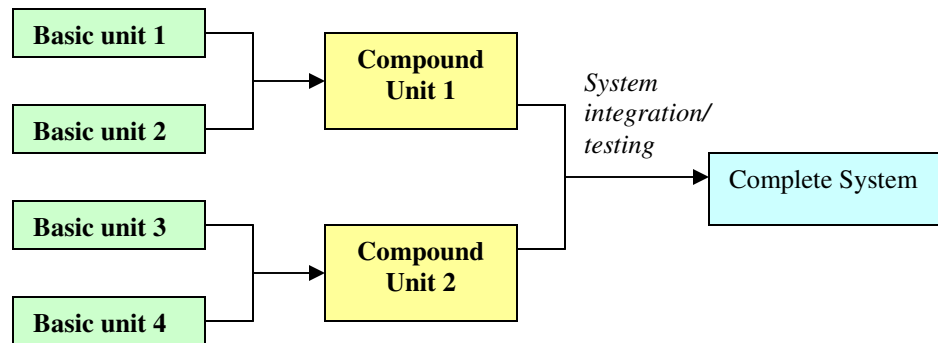

Figure 2. Hierarchical structure of practical project to build up design skills step-by-step.

## 2) *Exploratory Projects to Stimulate Interest and Enhance Understanding*

This kind of project focuses on stimulating students' interest in learning new concepts. Before the students are presented with the new knowledge, they will be assigned to work on an interesting demo project to explore the features of the design. The instructor will guide them to make “discoveries” on the available functions, and lead them to uncover the limitations of the design. Group discussions will be the next step to summarize the “discoveries” and to stimulate the next step of learning. It is important that the exploratory projects follow the natural learning process such that the students can learn otherwise abstract engineering concepts in a fun and effortless way.

We successfully used the exploratory project model to engage groups of young girls from junior high school to learn color theory and object detection algorithms during the Sally Ride Science Festival this past year. It would be practically impossible to deliver such in-depth engineering knowledge to young girls who usually find math and engineering less attractive if the lecture is conducted in traditional way (as shown in Figure 3(a)). Thus, we developed an interactive demo project using Tablet PCs that can perform simple color recognition and speak the color of the object detected in an input picture. During the workshop, the CPBL model was used as shown in Figure 3(b) to intrigue the girls into learning the subjects step-by-step. First, they work in groups to create images containing different colors and use the demo project to explore which color can be recognized correctly. Next, they discuss in groups why some colors cannot be recognized. The instructor provides some hints to guide their discussion. Then the answer is revealed and the color theory is presented. The CPBL model turned out to be very effective. The girls' responses were far beyond our expectations. They were so excited about the hands-on project, and were very engaged in exploring every feature of the color-recognition software. Learning became a natural process with embedded projects to stimulate puzzle-solving and discussion.

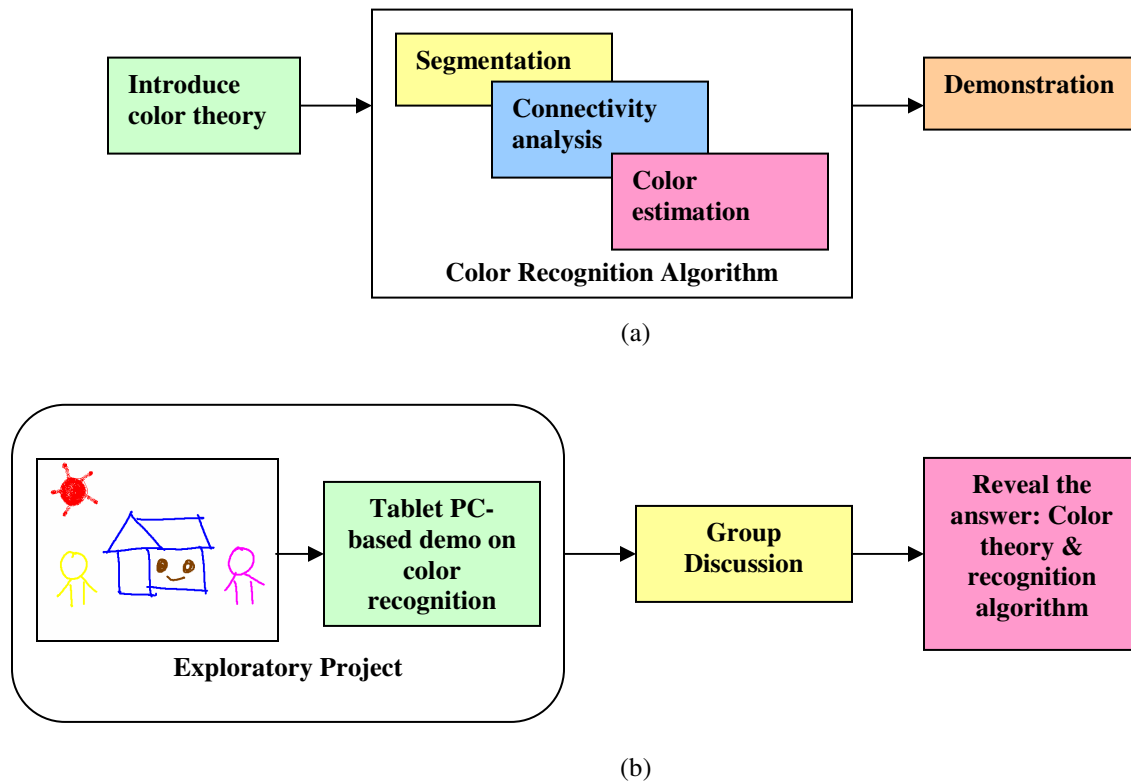

Figure 3. Comparison between tradition presentation and CPBL inspiring project: a) The tradition method to introduce color recognition algorithm; b) Using inspiring project to stimulate the students' learning.

### Implementation of CPBL Model in Engineering Courses

Our proposed CPBL model has been implemented in three pilot courses: Microcomputer Programming (EE345), Computer Logic Design (EE347), and Multimedia Networking (EE442). Originally, these courses were taught using traditional teaching methods such as blackboard delivery and PowerPoint presentation. Based on our past experience, no matter what instruction method is used, it is difficult to achieve a good balance between efficiency (how much content can be taught) and effectiveness (how much the students can understand). In addition, students have to do the course projects or programming assignments after class. Since many of our students have part-time or even full-time jobs, they cannot come to instructor's office for help. Due to lack of guidance, the completion rate of the projects was rather low. After the implementation of the CPBL model, a significant improvement has been observed. The details are described as follows.

#### 1) CPBL implementation in Multimedia Networking (EE442)

CPBL model was first incorporated in EE442 in Fall 2005. Courseware was re-designed to feature dynamic presentations and interactive demos. In addition, we developed software to conduct in-class polls to monitor the students' understanding of the course material and to

stimulate class discussion. Since the instructor can have a good sense of how well students understand the course material using real-time polling, the pace of the lecture can be adjusted to optimize the learning outcome.

To help students understand the principle of video compression/transmission and gain the necessary skills to design multimedia applications, a series of guided projects were developed. Here we use the online VCR project as an example to illustrate how to break down a big project into small pieces that allow students to learn the design process in a progressive way. In general, a video streaming system consists of two major components: server and client. The server should interpret requests from the clients, prepare video packets, and send them out. Thus it can be further divided into three modules to perform these functions. Similarly, the client will receive user comments (GUI), forward the user comments to the server, receive the video packets, and display the video. Hence, four modules are needed to build the receiver. It is relative easy to develop one module at a time following the instructor's guidance. In practice, a group of three students will be formed to work on the project, and they will divide work among themselves. One will develop two modules at the server, one will develop the GUI and video display at the client side, and the other will develop the transmission modules. After completing the components in the design process, the students grouped together to conduct system integration and perform testing. The instructor interacts with each group to provide guidance in each step of the design process, answer students' questions, and address any observed problems. The design results of each group can be easily demonstrated to the entire class using networked Tablet PC, as shown in Figure 4.

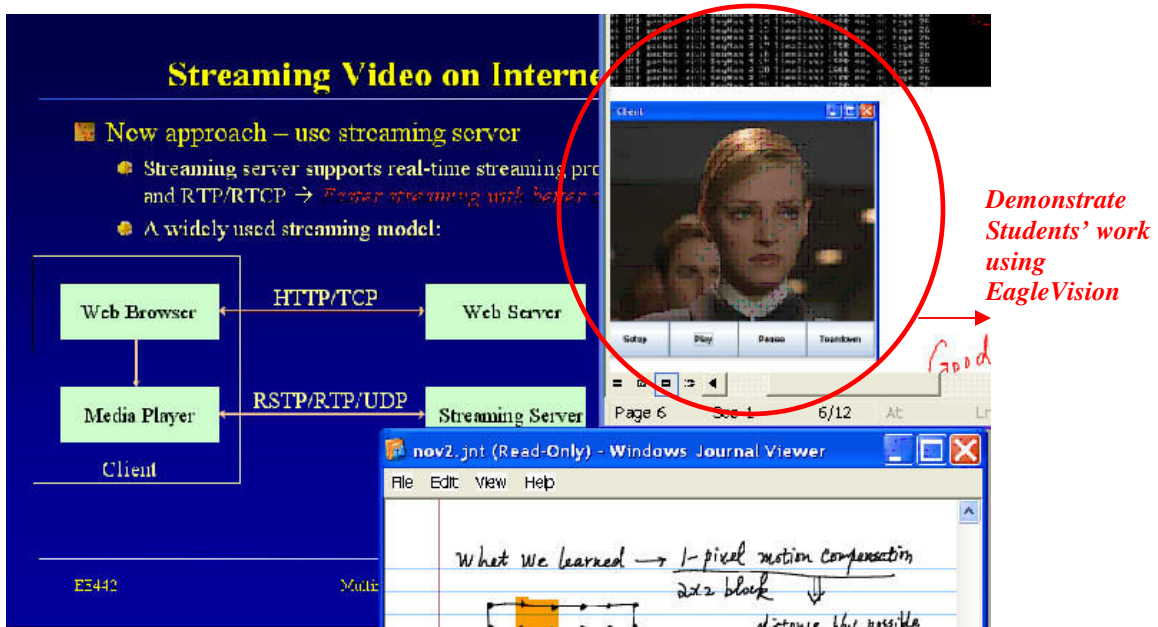

Figure 4. A Snapshot of Tablet PC presentation which broadcast students' work.

## 2) CPBL implementation in Computer Logic Design (EE347)

In EE 347 (Computer Logic Design), students learn the computer logic design process by designing a register file in class. First the instructor models the design process on a simple component such as a multiplexer. Next groups of two students design a system component such as a register or decoder. Then groups of four are formed to merge the designs into a register file. Using the Tablet PCs, students can seamlessly define the specifications of the circuit, sketch the design, implement it in Verilog HDL, and simulate it to verify its correctness. During the in-class assignments, students learn about the different roles of design and test engineers. They also learn about project management and how to define specifications that allow the test and design engineers to work in parallel. Finally, we teach them about the hierarchical nature of design by integrating designs from different groups into more complex systems. After students have learned the design process in class, they repeat the process in their collaborative term project, typically an arithmetic logic unit (ALU) designed using different modeling techniques.

## 3) CPBL implementation in Microcomputer Programming (EE345)

Due to the promising implementation results of CPBL in EE442 and EE347, we began to use it in EE345 starting from Fall 2006. Assembly language programming and microcontroller interfacing are often taught with a lab component or at least TA office hours. In lieu of those, we can integrate simple hands-on exploratory and development projects into the lecture. Years ago, our microcomputer programming course was taught in a laboratory with hardware. Recently it has been taught using a simulator that provides an integrated environment for programming, debugging and running. In exploratory projects, students work in small groups and use the simulator to explore the different instructions of the Motorola MC68HC11. Another example exploratory project teaches students how to effectively test their programs by having them develop sample test sets for different programs based on the characteristics of the program (types of inputs, outputs, and control paths).

The Tablet PC is also an ideal platform for teaching software development as shown in Figure 5. Students can learn to sketch their flow charts using Microsoft Journal and then develop their code side-by-side using the THRSim11 Simulator. As they develop their code, students can modify and refine their flow charts. The inking over capability is very useful in demonstrating the structure of the assembly and machine language as well as the features of the simulation software. It is also easy to highlight what is happening in the simulator as the program executes.

### **Preliminary Assessment**

To quantify the impact of CPBL model on student learning outcomes, assessment was conducted in each pilot course. Both direct and indirect measurements are used to achieve a comprehensive evaluation result:

#### Direct measurements:

- Scores on various course components such as homework, projects, presentation and exams are archived and compared to measure the students' understanding of course material, their design ability and overall performance.

- Classroom observation/evaluation were performed to measure the students' advancement in design ability, team skills and presentation skills exhibited by their in-class project and presentations.

Indirect measurement:

- Surveys of students' satisfaction were conducted in each of the pilot courses to evaluate the efficiency of student learning using Tablet PC from the students' point of view.

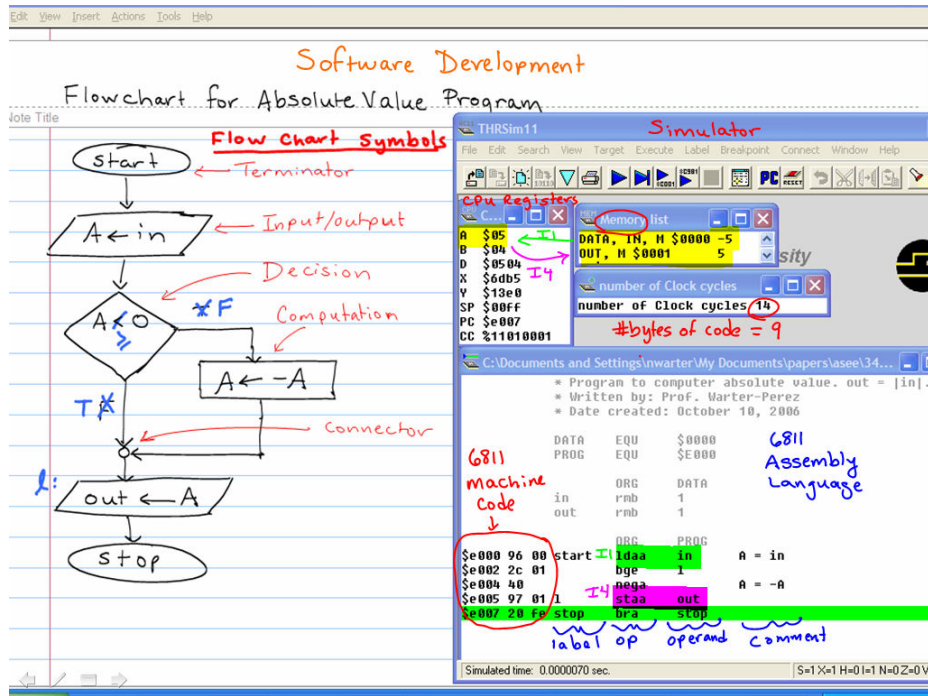

Figure 5. A Snapshot of Tablet PC presentation describing software development using Motorola MC68HC11 THRSim11 simulator.

In general, the results of direct measurements are very encouraging. Classroom observation revealed a significant improvement in students' design skills, presentation skills and team skills. This result is consistent with the score analysis which is depicted in Figure 6. As shown in Figure 6, the students' performance in various course components as well as their overall grade exhibited a consistent improvement after CPBL was implemented in 2005. Particularly, the completion rate of the term projects increased by more than 10% compared to the quarters before CPBL was used. Project presentation performance showed that the students had become more confident with the design process and more organized in presenting their design results.

In addition, the Students' satisfaction survey also returned positive results. Since the implementation of CPBL, the students' opinion on Tablet PC-based lecture and design project was collected. The following are the results from the student feedback in EE442 since 2005:

- ❑ Almost 100% of the students agree that Tablet PC-based presentation is better than PowerPoint slides;
- ❑ Around 90% of the students agree that Tablet PC-based presentation is better than blackboard presentation;
- ❑ Around 80% of the students prefer Tablet PC to traditional paper-based note-taking;
- ❑ Almost 100% of the students agree that Tablet-PC based project is very helpful in improving design skills.

In general, the preliminary assessment results indicate that our proposed CPBL model is very effective in enhancing students' design skills. However, since the implementation time of the model is still quite short, more assessment data is being collected for a more accurate evaluation.

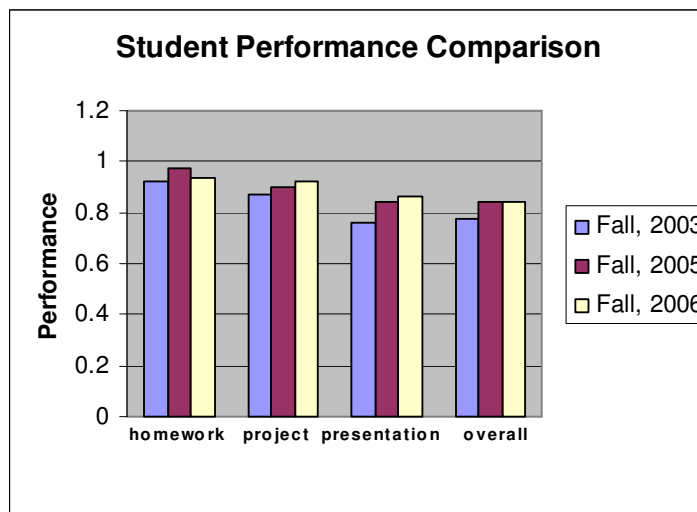

Figure 6. Student performance comparison in multiple course tasks in EE442.

Nevertheless, we did face some challenges when implementing the CPBL model in the pilot courses. As with any course re-design, it usually takes several iterations to “work out the kinks.” The biggest challenge is how to balance the instruction time and the time to do in-class projects. It is important that the in-class projects should not take too much instructional time. However, we found it somewhat difficult to control due to the wide diversity of our students' background knowledge and skills. One way to solve this problem is to host additional workshops to train the students on how to use the Tablet PC, but it does require the instructors to put in additional effort. In addition to training sessions, another approach is to host office hours where students have access to the Tablet PCs, perhaps immediately after class in the same classroom. This has proven beneficial as students near the end of their term projects and need additional help with testing and debugging their designs. Currently we are still working on optimizing the design of the in-class projects, and trying to find a way to administer in-class projects more efficiently.

## Conclusion

In this paper, we presented a Collaborative Project Based Learning model using Tablet PCs, with the objective to enhance students' design skills. The key component of this model is the design of a series of small in-class collaborative projects that help the students to gain the knowledge and skills in a progressive way. Successful implementation of the proposed model in three core computer engineering courses demonstrated a new solution for improving the instructional efficiency in the engineering classroom and for seamlessly incorporating the design practice in lectures. Initial assessment results shows that the impact on students' learning outcomes is very promising. In our future work, more comprehensive assessment data will be collected and analyzed, and the findings will be used to further improve the engineering curriculum.

## Acknowledgment

This work is sponsored by Hewlett-Packard. The authors would like to thank HP for their continuous support to higher education.

## Reference

- [1] A. J. Dutson, R. H. Todd, S. P. Magleby, and C. D. Sorensen, "A Review of Literature on Teaching Design Through Project-oriented Capstone Courses," *Journal of Engineering Education*, pp. 17-28, 1997.
- [2] D. L. Evans, B. W. McNeil, and G. C. Berkeley, "Design in Engineering Education: Past Views of Future Direction," *Engineering Education*, vol. 80, pp. 517-522, 1990.
- [3] K. Smith, S. Sheppard, D. Johnson, and R. Johnson, "Pedagogies of Engagement: Classroom-Based Practices," *Journal of Engineering Education*, Vol. 94, No. 1, 2005, pp. 87-102.
- [4] R. Anderson, L. McDowell, and B. Simon, "Use of Classroom Presenter in Engineering Courses," *Proceedings, 35<sup>th</sup> ASEE/IEEE Frontier in Education Conference*, Oct. 19-22, Indianapolis, 2005.
- [5] T. Denning, W. G. Griswold, and B. Simon, "Ubiquitous Presenter: Enabling Student Control and Access in a Digital Environment," *Proceedings, EDUCAUSE Learning Initiative Meeting*, Jan. 29-31, San Diego, 2006.
- [6] V. Diaz, V. Piscitello, M. Sechrest, and L. Small, "Integrating Tablets and Mobile Technology: Breaking down the Large Class Through Active Learning, Practice, and Faculty Engagement," *Proceedings EDUCAUSE Learning Initiative Meeting*, Jan. 29-31, San Diego, 2006.
- [7] J. Tront, V. Eligete, and J. Prey, "Effective Classroom Presentations using Writeon," ASEE annual Conference, June, Chicago, 2006
- [8] S. Lord, "Tablet PC – Is It Worth It? A Preliminary Comparison of Several Approaches to Using Tablet PC in An Engineering Classroom," ASEE annual Conference, June, Chicago, 2006
- [9] H. Ning, J. Williams, A. Slocum, A. Sanchez, "Inkboard – Tablet PC Enabled Design-Oriented Learning," *Seventh International Conference on Computers and Advanced Technology in Education (CATE 2004)*, Kauai, Hawaii, USA, August 2004.

[10] R. Nathan, "Integrating Multimedia Aids (Tablet-PC, Streaming videos, Electronic Slides) to The Fundamental Instruction in Mechanics," ASEE annual Conference, June, Chicago, 2006

[11] N. Warter-Perez and J. Dong, "An Active Learning Teaching Model for Engineering Instruction based on Mobile Technology", ASEE PSW Conference, April, Pomona, 2006