

AC 2007-237: BIG PICTURE, RATIONAL, ENGINEERING DESIGN METHODOLOGY

Andrew Foley, U.S. Coast Guard Academy

Dr Andrew C Foley P.E Associate Professor, U.S Coast Guard Academy, New London CT

Big Picture, Rational, Engineering Design Methodology.

Dr Andrew C Foley P.E.
U.S Coast Guard Academy,
New London, CT

Summary

Frequently in the teaching of design, instructors launch into an idealized sequence of identifying clients, their needs, setting objectives, planning, generating ideas, evaluating alternatives etc. Whilst no doubt beneficial in undertaking successful designs, what is often overlooked is an upfront assessment of whether or not a new design is genuinely required or really what prospective clients need. In the author's personal consulting 'design' work it has frequently been found that the optimal solution path has been the identification of pre-existing designs and hence many contracts have been reduced to decision making processes. This has undoubtedly saved the client time and money and although not the client's original intent is invariably a more successful contract conclusion. This paper describes a design sequence taught by the author whereupon elements of a Master level management course, previously taught by the author, have been grafted into the front end of a sophomore introductory mechanical design course. The techniques used are not too dissimilar to many of the design process methods already taught in the traditional sequence and hence there is no great increase in the abstraction or the quantity of material required. Rather the sequence, context and range of application are altered. If the techniques discussed do ultimately determine the necessity of undertaking a design process the paper goes on to re-affirm the importance of sketching and 'guesstimation' techniques within the traditional design process.

To summarize, the paper describes an alternative 'big picture' design sequence which is hopefully unique enough to avoid the classification of 'just another idealized design process'.

Introduction

Imagine the scenario of a patient with a broken arm seeking help from a tree surgeon. We would hope that before diving into the complexities of fixing a broken arm the tree surgeon would look at the big picture and re-direct the confused patient to an appropriate medical practitioner, perhaps along the way handing out a business card. Such a far fetched scenario is quite often not far from the mark for the engineer. Indeed many 'design' problems are often presented in such eloquent and well specified formats that the engineer often feels obliged to dive into a design process. Despite this, it is imperative to take a step back from the initial project proposal, problem description, etc. and undertake a situation appraisal.

Front loading design with the 'Big Picture'.

Kepner Tregoe (1981) calls it Situation Appraisal, the Army calls it 'the estimate of the situation', the Coast Guard 'preliminary incident management' and so on and so forth. Basically it is the process whereby you establish a datum or starting position. Only then can subsequent actions be evaluated as beneficial or detrimental to the status quo. The

proverbial 'going around in circles' and quite literally being 'lost' in a design process are invariably a direct result of failing to undertake this datum setting.

So important is the 'Situation Appraisal' that it should be undertaken, without exception, whenever a new project, appointment, promotion etc occurs. With ongoing projects and design exercises the situation appraisal should be undertaken at regular and frequent intervals. It is in essence a method of generating and maintaining a working to do list.

Of particular importance is undertaking a situation appraisal even if presented with a well specified design problem. Often this can be difficult as clients will often see this as unnecessary and unrelated work being undertaken at their expense. In such circumstances it is possible to veil the analysis as background research or data gathering which ultimately will be required anyway.

The methodology described in part by Kepner and Tregoe is the author's preferred option in introducing this process and each step will briefly be described below :

- i. List all concerns regarding the project, process, new job etc. No matter how trivial or seemingly irrelevant these should be listed with a supporting description. The order at this stage is not important but the comprehensiveness and range of issues is encouraged to be as large as possible.
- ii. Separate and Simplify concerns. Frequently issues are clouded and overlapping, particularly with large project teams. A goal therefore is to take out repeating issues and reduce 'complex' issues, if necessary to multiple simpler issues.
- iii. Prioritize based on risk and consequence. Once reduced to the 'bare bones' the concerns are examined with respect to the probability of them occurring and of the resulting severity of any consequences.
- iv. Assign a solution method. The prioritized list is then examined and the process required for resolution determined. Typically resolution methods fall into one of following categories :
An 'unidentified cause' problem that needs resolving, a future potential problem, a decision that needs to be undertaken or finally, a new 'solution' design requirement.

Kepner and Tregoe identify only the first three of these solution techniques as :

(a) Problem Analysis (PA):

The identification of an unknown cause resulting in an observed unwanted performance deviation

(b) Potential Problem Analysis (PPA):

Future problems that need to be solved with Preventative Actions or Contingencies (which can mean potential new design solutions)

(c) Decision Analysis (DA) :

This is where a concern is resolved by making an appropriate decision. This type of resolution could potentially initiate another decision process or any of the other resolution processes described herein.

(d) Design Process Initiation .DP.

This final method of resolving a concern is not included in the Kepner Tregoe method but instead is somewhat taken for granted as being a straightforward process turned to after a problem cause has been identified. Note that this omission is considered by this author to be somewhat tragic as although the KT method is targeted towards the manager, a lack of appreciation of the design process is arguably a cause for many woes in the developed nations' industrial sectors.

The design process initiation is normally where most undergraduate design courses kick off. Typically a multi-step method (See Hyman (2003)) is described, and although some iteration is foreseen the process is fairly sequential. Within conventional design many of the other problem solving processes will be called into action (i.e. Decisions, potential problems and even nested new design issues.) The key to this big picture approach is therefore to recognize that these processes are not so much sequential, but to use some computer terminology, direct access processes. Each being called upon as required to assist in the common goal of converging on an optimal solution.

Figure 1. is a schematic of how a big picture analysis would operate. After undertaking a situation appraisal a number of prioritized concerns would be identified. Many of these will be decisions, potential problems or problems with unknown causes. (The three KT identified concerns.) These can be solved by undertaking a conventional decision making process to solve the decision concerns. Potential problems will be solved by planning preventative actions to eradicate the problem or coming up with contingencies in case they come into existence. There is however a possibility that they will require a design solution and hence the dotted path to the design process. Problems with unidentified causes will be resolved by identifying the cause using techniques described by KT and implementing a solution if it is readily available. Again, it is possible that after the problem's cause has been identified no readily available solution exists and hence we may have to enter the design process. Again another dotted path shows this possibility. Finally there is the solution requirement of initiating a design process. Once initiated, the design process itself, shown by the bold double line, will then make use of the other three processes.

It is important to express that this schematic is not intended to show all permutations or possible paths to an optimal solution. The separate processes however are all invaluable skills for the designer and being competent in each can allow them to be called upon, documented and recognized for what they are and what they are trying to achieve. How they all flow together in the schematic can then be used to keep a 'project' (i.e. situation appraisal and concern resolution) focused and on track.

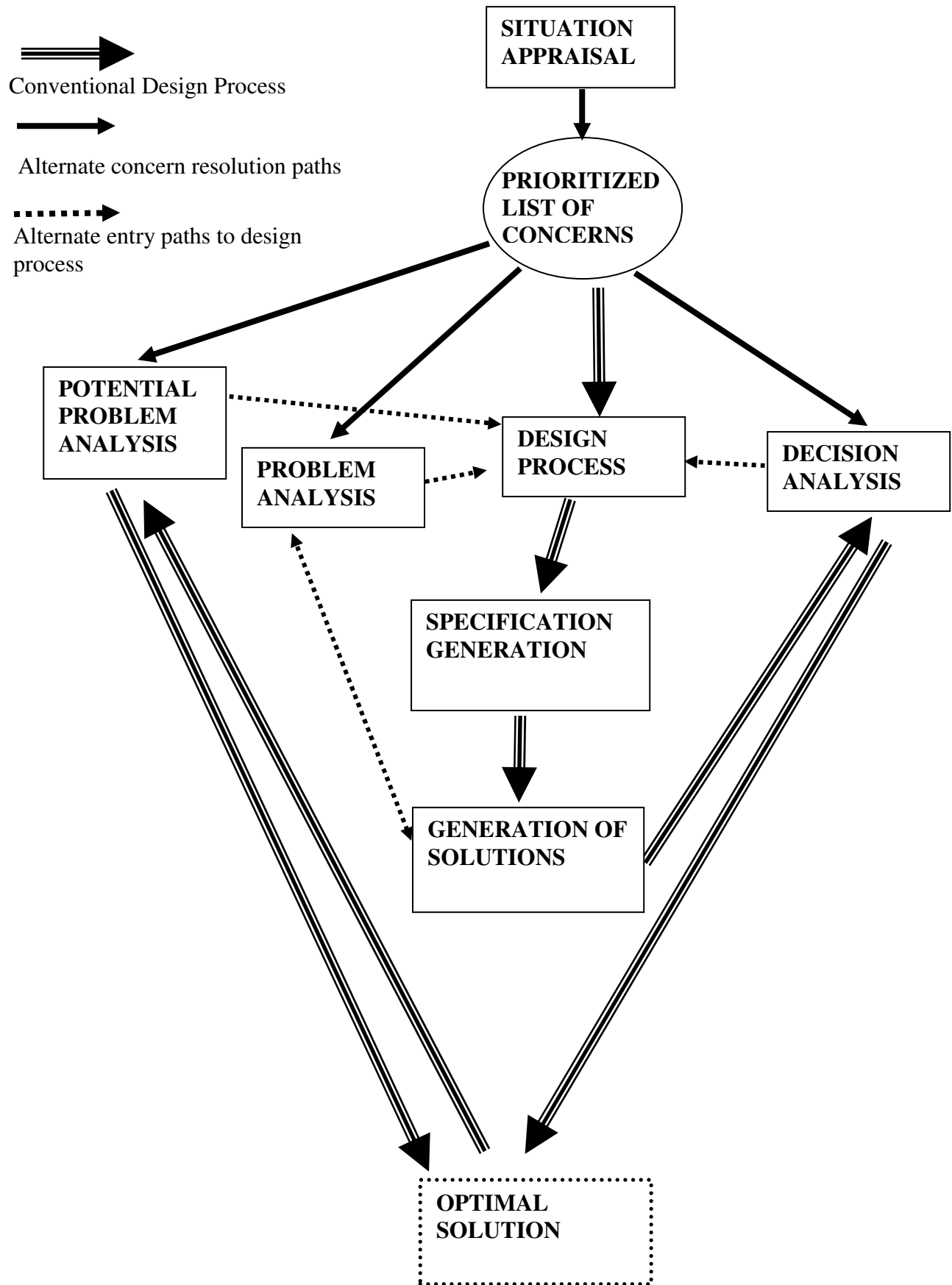

Figure 1. Schematic of the 'Big Picture' design process.

Other basic ‘big picture’ skills required in the design process.

Sketches

Within undergraduate programs there has been an explosion of computer aided design (CAD) and computer aided engineering (CAE) software packages. These are truly remarkable aids to engineering which unfortunately tend to draw emphasis away from the ability of an engineer to undertake good sketches. The sketch as a means of communication cannot be underestimated. More often than not, most great ideas, insights and general ‘eureka’ moments occur when computers are not readily available. The interaction one can have with others over a sketch is also hard to beat. The information density in a sketch also far surpasses that of the written word, the old adage ‘a picture is worth a thousand words’ still stands true today. The sketch also, by its very informality, encourages others to contribute to its development and the use of a pencil generally forms no technological barriers. All in all, it remains a tremendous tool for design and so should commandeer its fair share of a design course’s allotted time.

‘Guesstimation’

With most ‘design’ courses, particularly introductory sophomore level courses, tremendous difficulty is experienced by students with the open ended nature of problems. In most of their academic career, analytical science/technology courses invariably set well posed problems. (E.g. solve for three unknowns given three equations). As such students become accustomed to the ‘one correct answer’ syndrome which is usually achieved by drawing on methods and processes that have recently been taught in the same course. An expectation arises, frequently bordering on dependence, which means that when then faced with open ended, multi solution problems, students quickly become frustrated and incapable of progressing to a valid solution.

Because of the nature of the introductory design courses taught early in the sophomore year at many institutions, instructors can not expect a wide range of applied engineering skills to be available. (i.e. Thermodynamics, Fluid Mechanics, Machine Design, Strength of Materials etc.) As such in teaching introductory design, emphasis is placed on the process of reaching design solutions, rather than on the technical skills needed to accomplish this. This rationale is supported by most MBA’s who believe they can manage a technical company without any intimate knowledge of the technology. A belief, one may arguably disagree with, but seen to be true if one considers the number of non engineers/scientists running technical corporations.

In order to progress to a solution therefore, reliance is made of the use of justified approximations fondly referred to by this author as ‘guesstimations’.

In essence problems are simplified to the extent that analytical skills already possessed by sophomores can be utilized. Typically this means Newton’s second law, geometric relations, basic algebra, chemistry and physics. The key to success in using the method is to justify approximations whilst appreciating their limitations and then to carry the calculations through the several steps required to arrive at a ‘ball park’, order of magnitude solution.

Whilst using 'guesstimation' in a sophomore course on design is almost a necessity due to the lack of depth in student skill base, the method is not to be considered a second rate substitution for full blown analysis. Indeed, as skill sets are widened through out the rest of their academic and professional careers students are instilled with a mantra that before instigating any kind of detailed analysis, an initial preliminary solution should be assessed using guesstimation. The benefits being first to see if the solution process is valid and secondly to assess the order of magnitude or scope of any final solution. The preliminary solution will also act as a check on any final detailed solution. Many is the time that final, nine significant figure solutions have been wrong by orders of magnitude because the detailed solution had missed some major boundary condition or had used material or data with very large uncertainties. Indeed the whole practice of uncertainty analysis is somewhat neglected, or at best abused, and could easily form the basis of another paper.

Preliminary solutions also help avoid the 'analysis paralysis' syndrome so often encountered by inexperienced engineers. This occurs when the engineer attempts to dive into a new or unfamiliar problem with the intent of producing a detailed solution 'straight out of the gates'. Invariably, as the focus goes to the minutiae the influence of external factors is lost or undetermined and the solution grinds to a halt, only progressing when frequently obscure, invalid and potentially dangerous approximations are made.

Finally, as has been the authors own personal experience, preliminary solutions have often provided enough information that even with acknowledged limitations and uncertainties they have proved sufficiently accurate to provide an optimal solution at minimal cost.

Computer aided design (CAD) and closely linked machine shop practices.

Whilst harping on about the importance of sketching the author is the first to acknowledge the invaluable tool that CAD has become. It still astounds me that sophomore students after a mere 10 to 12 hours of tuition are capable of producing three dimensional complex parts and multiple part, three dimensional animated models along with their associated drawings. See figure 2 for an example of the air engine project undertaken at the Academy.

By combining the CAD laboratory with a concurrent machine shop experience, parts drawn are quickly manufactured and a symbiosis occurs. Previously CAD proficient students had produced impressive models and drawings for project parts. The subsequent manufacture of these parts though had invariably taken considerably longer and proved more difficult than expected, as without an appreciation of tolerances or machine capabilities parts had been designed which were impractical for manufacture.

To address this issue, the inclusion of an extensive machine shop experience embedded within the design course, has proved tremendously beneficial. Typically, students will commence with the manufacture of two test pieces, one turned on a lathe and one produced on a mill. (See figure 3). With a typical class size of twenty the resulting test pieces also provide a useful population for undertaking a statistical analysis on what tolerances could be expected for test parts produced with the available machines and student skill set. Later, drawings and project parts are produced with an appreciation

of these facts any many of the issues mentioned above have diminished. i.e. Parts are being designed for manufacture as well as function.

At a time when the expense of running a machine shop results in many institutions closing down such components of their program it cannot be stressed strongly enough that this really is an invaluable part of any engineer's education. To reduce financial burdens therefore, the author advocates the use of multiple, inexpensive, manual machines as opposed to fewer more complex and expensive computer numerical control (CNC) type machines. Complex machines often offer greater opportunity to 'mess up' and damage parts and hardware and as such tend to be more supervised and removed from direct student involvement. Experimentation and learning by doing is discouraged and access is severely curtailed. Manual machines on the contrary, can provide all, if not more, of the educational benefits that are desired for undergraduate projects and although tolerances and finishes etc may not be as good as on a CNC machine, an appreciation of them is at least realized. Often the set up time for one off components is also considerably reduced and students can eventually be allowed to machine out of class hours with minimal supervision.

U.S Coast Guard Academy design courses

There are two main design sequences in the four year mechanical bachelors program at the U.S Coast Guard Academy. These are the Introduction to Mechanical Engineering course (IMED 1208) taken in the sophomore (second year) and then the Senior Mechanical Engineering (Capstone) Design course (1446) taken in the final semester.

The two courses comprise a lecture component of two one hour sessions backed up by official 'laboratory' periods of three hours. In reality the labs take up considerably more time and become what is hoped to be a 'labor of love', with students pushing their projects beyond the course minimum requirements. Lectures basically follow the same sequence covering topics such as decision making methodology, specification generation, risk analysis, codes and standards, ethics, economics, etc. The difference between the two courses is in the depth of topic coverage. IMED requiring relatively shallow coverage with the focus being on the process steps in the design method. The senior course takes knowledge of these steps somewhat for granted and instead the focus is on increasing the depth and scope of problem definitions, detailed analysis methods, proficiency in communication and the size and complexity of the projects undertaken.

Laboratory exercises for the introductory course are much more structured, with only a small student driven design exercise at the end of the course. The senior lab is from the outset, a student driven design exercise, the projects being generated and selected by the students in the previous semester.

Conclusion

The 'big picture' is the front end loading of a design course with the teaching of an overview process within which design is only one possibility. Undertaking a situation appraisal and resolving prioritized concerns into problems, potential problems, pending decisions and finally, design initiation is discussed. With an appreciation of these different resolution processes, what is believed to be unique in this approach is the stressing that just because one becomes an engineer, the answer to all concerns is not necessarily the initiation of a design sequence. What is also appreciated is that these alternative resolution techniques can, and are frequently, called upon throughout a conventional design process. With these upfront considerations highlighted the paper then also discusses the importance of emphasizing good sketching, 'guesstimation' and machine shop skills. All topics of a design course which also play an important part in recognizing the 'big picture' and tools that ultimately make the engineer not just a better designer but, in the bigger picture, a better and more successful 'concern resolution' specialist.

References

Kepner C.H, Tregoe B.B,(1981) *The New rational Manager*, Princeton Research Press, NJ,USA, Library of Congress no. 80-84367

Barry Hyman (2003) *Fundamentals of Engineering Design*, 2nd Edition. Pearson Education, New Jersey. Pp 8-15. ISBN 0-13-046712-X

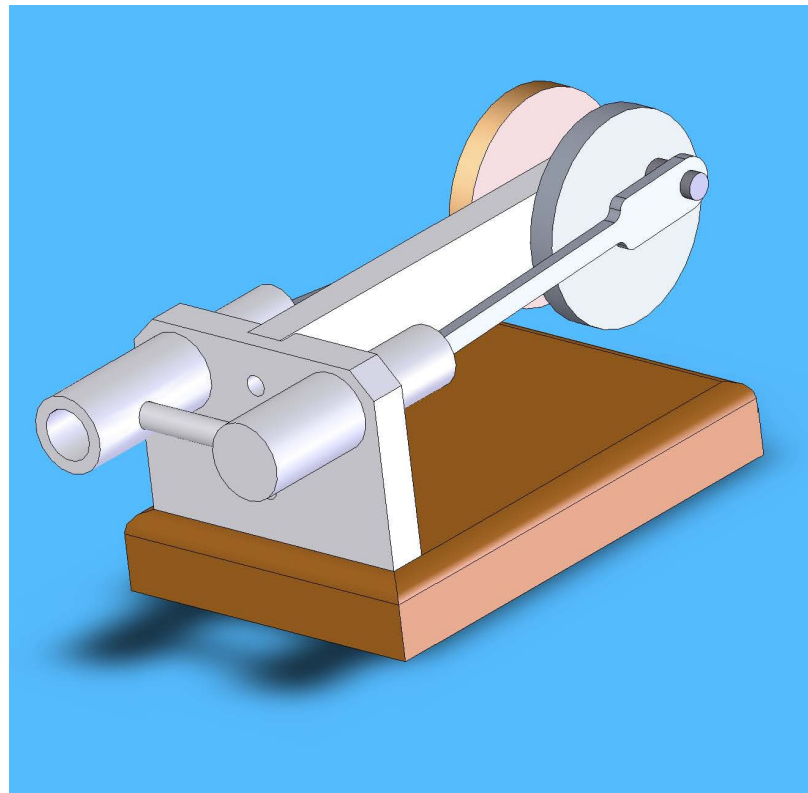

Figure 2. Air engine computer aided design and manufacture project.

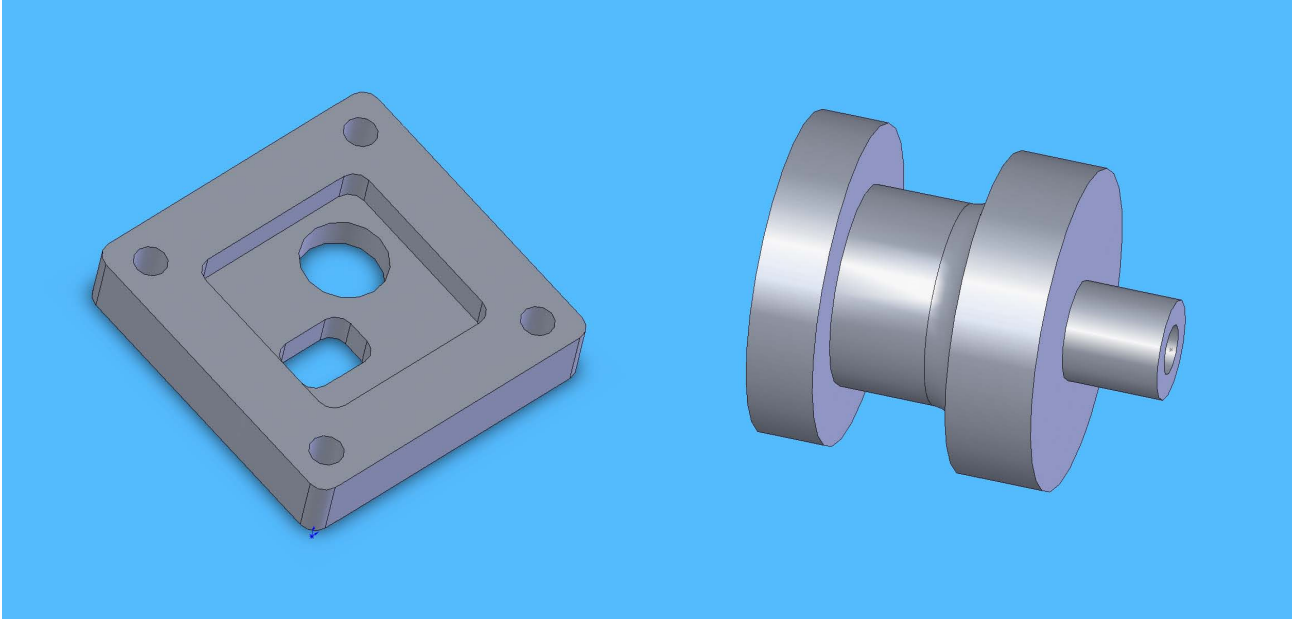

Figure 3. Manufacturing, mill and lathe, test pieces.