

AC 2007-238: IMPROVING LEARNING OF ENGINEERING GRAPHICS THROUGH A COMBINATION OF TECHNIQUES

Keith Fisher, University of Maine
Montana State University

Kevin Cook, Montana State University

Improving Learning of Engineering Graphics Through a Combination of Techniques

Abstract

The quest for improved learning of engineering graphics communications skills is of continued interest to many institutions. Prompted by observed deficiencies in graphics communication skills in students, the Mechanical Engineering Technology program at Montana State University has undertaken a revision of teaching methods; utilizing a combination of simple strategies, with the goals of re-emphasizing the communications aspect of engineering graphics, giving students improved tools and techniques for drawing, modeling, and analysis, and increasing learning and retention of those techniques. The individual methods used in combination include: extending the graphics exposure throughout the first three years of the curriculum, making the courses design project centered - with the integrated physical production of the projects as an essential part of the learning process, adopting a “corporate work environment” in some portions of the classes, emphasizing the use of reference materials in the design and drawing process so that students will learn to be resourceful life-long learners, and using both individual feedback, and self-evaluation techniques as reinforcement. This combination of methods has shown preliminary promise of improving the learning and retention of graphical communication capabilities and performance for engineering students, both while in school, and beyond.

Introduction

This paper details the ongoing work to revise the learning of engineering graphics in the Mechanical Engineering Technology program at Montana State University, and to integrate the learning of graphics more thoroughly with the other courses in the program. The revision is part of a more comprehensive revision of the entire program curriculum¹, currently underway.

This program, like one other the author was associated with at another university, has seen deficiencies in the performance of students in the area of graphics utilization later in their academic careers. For example, the third year students have exhibited difficulties in conceptualizing and utilizing graphical solutions to vector problems in kinematics, and senior students have struggled with producing quality documentation of their capstone design projects. These observed deficiencies may be due in part to the compression of engineering curricula in years past which has relegated engineering graphics solely to a two credit first year Computer Aided Design and Drafting (CADD) course, with very little follow-up, or use, until the fourth year design projects, during which time the students seems to have lost connection with what they should have learned in the first year. Feedback obtained from the Industrial Advisory Board for the department, as well as employer and alumni surveys, has verified these deficiencies and the need for improving the graphical communications education in the MET program.

Approximately 92% of the typical design process is graphically based², and industry is utilizing visual modes of communication in greater amounts and variety, yet many engineering and technology curricula have seemingly let engineering graphical communication learning lapse. In response, the curriculum revisions at MSU were undertaken to improve the learning of engineering graphics through modification of material coverage and teaching style.

Goals

The overall goals of the engineering graphics curriculum revision were as follows:

- 1) Re-emphasize the essential purposes and importance of communication through graphics needed by engineers and design professionals.
- 2) Give the students improved tools for graphics communications which, in a generalized manner, represent the range of methods and programs used in the industries in which they will likely be employed.
- 3) Improve the learning and retention of these graphical communication techniques and tools through a revision of the teaching approach, and change of exposure to the subject with integration throughout the program curriculum.
- 4) Increase the student's capabilities in problem solving, spatial analysis, and logical design thought processes earlier in the program.
- 5) Provide students with understanding of computer aided analysis fundamentals that will be practical and transcend the particular software used.

Core Competencies in Engineering Graphical Communication

These revisions are designed to enable the school to achieve the following desired Graphical Engineering Communication Core Competencies of MET students at MSU:

- A. To be able to effectively communicate engineering design information through:
 1. Engineering Sketches,
 2. 2-D CAD drawings, layouts, schematics, etc.,
 3. 3-D Solid Models,
 4. CAM programs, and
 5. Computer Aided Analysis Programs.
- B. To be able to produce engineering communication that conforms to common engineering communication (drafting) standards (ANSI, ISO, AWS, etc) including Geometric Dimensioning and Tolerancing (G, D, & T) standards.
- C. To be able to utilize the above methods and programs efficiently in design and to understand the proper role of geometric fits and tolerances in graphical design.
- D. To have a fundamental working knowledge of CAM as it is used in industry today.
- E. To have a general and fundamental working knowledge of Finite Element Analysis, Simulation, and Computational Fluid Dynamics with an

understanding of the benefits and the pitfalls of common desktop programs in use in industry today.

Methods

A variety of methods are being blended together to achieve the above goals, including:

A. Careful choice of graphics tools (programs) and methods.

Tools for graphical communication and design are changing continually, as many others have already noted,³ however a number of important categories of tools are readily discernable.

- 1) The first of these is that there will always be a place in the design process and communication of ideas for hand sketching.
- 2) Second, many enterprises still make ample use of 2-dimensional CAD programs and drawings for layouts, schematics, and design documentation.
- 3) Third, the use of solid modeling software is widespread in industry, and it has demonstrated its value in product design.
- 4) Fourth, analysis and design tasks have benefited greatly from the use of specialized Computer Aided Engineering (CAE) tools such as Finite Element Analysis (FEA), simulation programs, and Computational Fluid Dynamics (CFD) software.

Each of these four categories of tools is well represented in the program revision, but the selection of the particular software tools has been carefully made so as to keep the time spent mastering computer programs to a minimum, and to allow the maximum time for learning to effectively design, and communicate design information, with the use of the chosen tools. AutoCAD^{®4} was chosen as the 2-D program because of its wide use across several industry sectors, and SolidWorks^{®5} was chosen for the 3-D program because of comparative ease of learning, range of professional capability, and integration of modeling and analysis functions within the educational software package available.

B. Increased and progressive exposure to graphical communications.

In order to provide for integration with the rest of the course curriculum and reinforcement of concepts learned, the curriculum has been revised and improved to provide graphics courses during each of the first three years of the typical four year plan.

1st Year:

MET 119 Technical Graphics Communication-Intro. to Communicating with 2-D and 3-D CAD

2nd Year:

MET 211 Graphics in Design – Graphical design modeling methods, fits, GD&T, tooling, etc.

3rd Year:

MET 303 CAE Tools in Mechanical Design - Modeling, FEA, CFD, Simulations, CAM, RP

C. Improved teaching methods.

The method of teaching is being altered to maximize the learning experience and retention by:

- 1) Carefully relating each concept and method presented to its role in real-world graphical communications, so that the connection to application and practice is clear.
- 2) Utilizing design/draw/build projects throughout the curriculum. Project based learning has been shown to improve the learning experience and retention through increased student participation, and understanding of the relationships of concepts to, and details of, the applications⁶. Our choice of using projects that are real items (typically shop tools such as drill press vises, hammers, and shop measuring instruments) that the students design, draw, and build themselves, also boosts interest and involvement by inspiring ownership of the project.
- 3) Mimicking a corporate design environment in some cases. The use of a classroom environment that, at times, seems more like a corporate work atmosphere than a traditional classroom, is for the purpose of encouraging students to take even greater ownership and responsibility for their project, and thus deepen their learning experience.
- 4) Encouraging students to learn to use available reference material. By prompting students to go to reference material for at least a portion of the information they need to be successful in their project design and drawing, they are made to be more resourceful – which will be needed for success later in their academic and real-world careers.
- 5) Improving immediate personal one-on-one interaction in the classroom between instructor and students to provide ample feedback on their projects, increasing experience, and teaching them to check and evaluate their own work.
- 6) Conducting all of the classes in the computer lab, with a minimum of lecture, and an emphasis on applications and practice, in an effort to be learning centered vs. teaching centered⁷.

D. Assessment in each course will be integrated with other courses.

Assessment of learning will include exit surveys and exit skills assessment for each course, and additional entry skills assessment for the second and third year courses to ensure that material is not only being learned, but learned in such a way as to be retained. The assessment tools are being developed along with assessment of the entire curriculum revision assessment.

The following description of course layouts illustrate how these methods are being implemented to achieve the stated goals:

New Course Structure

The first year course (MET 119) uses both projects and exercises to introduce the role that graphics plays in design and communication of ideas to and from the designer, as well as exploring a range of types of engineering graphical communication. Students

learn visualization, sketching, and geometric construction; learn and compare 2-D CADD and 3-D solid modeling methods; understand what comprises good communication in drawings (such as clarity and standards); and are introduced to the use of graphics in designing for specified fits and tolerances. Core competencies A, B, and C, (previously listed) will be partially addressed in this course. Learning will be assessed through skills tests and project grading, as well as an exit survey.

In the second year, the course (MET 211) focuses on using graphics in design (3-D modeling design methods, fits, tolerances, hardware and tooling considerations, geometric dimensioning and tolerances, etc.). This is done in a project design environment which somewhat simulates an industrial work setting, where students design and complete all documentation (specifications, sketches, models, drawings, parts lists, user manuals, etc.) for real assemblies that they will build themselves. In order to assist the students in becoming resourceful, life-long-learners, a reference book⁸ is primarily used in this course instead of a more conventional text. Having the opportunity to design, draw, and build the project gives students the chance to personalize the essential questions of: How will this actually be built, and what information must be communicated to allow it to be produced? Additionally, topics such as product life cycle management, product data management, and concurrent design are introduced. Core competencies A, B, and C, (previously listed) will be addressed in this course. Retention of material learned in the previous course (MET 119) will be checked at the beginning of this course and learning assessment at the end of the course will be through skills tests and project grading, as well as an exit survey.

The third year course (MET 303) introduces the students to the more advanced CAE tools – spending time on understanding of their proper use and interpretation as well as giving experience in how to use them through exercises and projects, modeling for analysis, rapid prototyping, and computer aided manufacturing (CAM) techniques and tools. Ethical considerations will also be discussed. Core competencies A, C, D, and E, (previously listed) will be partially addressed in this course. Retention of material learned in the previous course (MET 211) will be checked at the beginning of this course and learning assessment at the end of the course will be through skills tests and project grading, as well as an exit survey.

Other courses in the curriculum that will be further integrated to utilize the material and methods taught in the three graphics courses include: Kinematics, Machine Design, Welding, Machining, Senior Capstone Design and some of the Professional Electives.

Figure 1, the flow chart of the new MET curriculum, gives an indication of the integration of these courses into the program and how they interface with other courses.

Preliminary Results

The courses are being introduced to the students progressively beginning with the first year course in the 2006-2007 academic year, the second course to follow in the 2007-2008 year, and so on. However, the author's experience with the introduction of a course

essentially identical to the second year course during a previous teaching assignment in the spring semester of 2006, showed positive attitude shifts on the part of the students.

1. The students were enthusiastic about, and engaged with, the design/draw/build process.
2. Students gained realistic, practical understanding of the design process.
3. Students expressed surprise and respect for the amount of information needed to communicate a design to production personnel.
4. Students gained understanding in how to utilize reference material for designing projects.

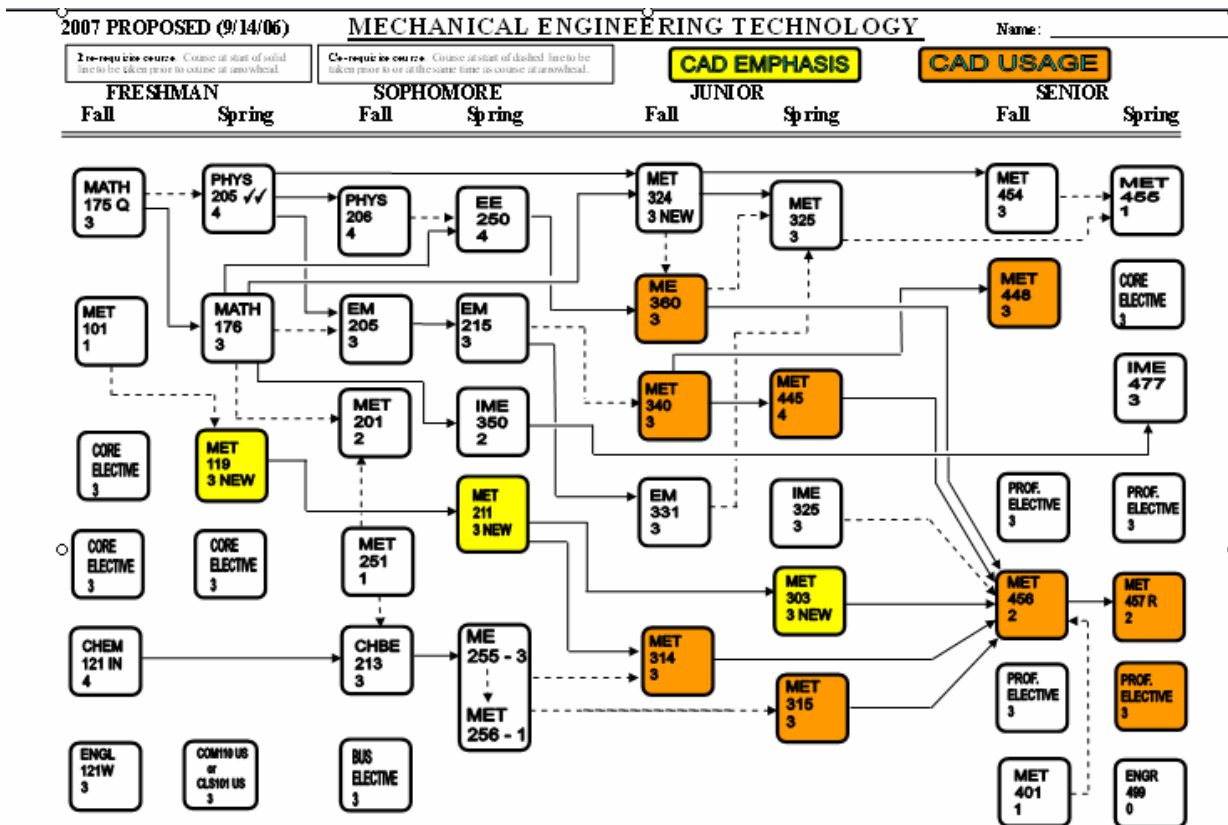

Figure 1. Flowchart of Graphics Emphasis and Usage in the MET Curriculum.

Summary

Engineering graphical communications in Mechanical Engineering Technology at Montana State University is undergoing a thorough revision to improve learning and retention of graphical and visual methods of design, problem solving, analysis, communication, and documentation. The methods by which this is being accomplished include the use of improved timing of exposure and integration into the curriculum, a considered choice of tools and programs, the use of a combination of design/draw/build projects, modified class working environment techniques, and more interactive feedback from the instructor. Implementation is underway and early indications are that it will be a positive change for student learning. Assessment will be collected at the end of the

freshman year, as well as at the beginning and end of the follow-on courses, and appropriate adjustments made as needed to support the goals of student learning, and expectations of the program and its constituents.

Bibliography

1. Cook, K., Larson, R., Fisher, K., *Mechanical Engineering Technology Curriculum Enhancement: Preparing Graduates For Future Professional Success, Proceedings of the 2007 ASEE Annual Conference and Exposition*, Honolulu, Hawaii, 2007-2252 (Proposed)
2. Bertoline, G. R. and Wiebe, E. N., *Fundamentals of Graphics Communication, Fifth Edition*, McGraw-Hill, New York, NY, 2007.
3. Holdhusen, Mark, *Design of an Engineering Graphics Course for a Pre-Engineering Program, Proceedings of the 2006 ASEE Annual Conference and Exposition*, Chicago, Illinois, 2006-1051.
4. Autodesk Inc., 111 McInnis Parkway, San Rafael, CA 94903
5. SolidWorks Corporation, 300 Baker Avenue Concord, MA 01742
6. Palmquist, Shane, *Project-Based Learning in Engineering Mechanics: Inspection and Analysis of a Historic Truss Bridge, Proceedings of the 2006 ASEE Annual Conference and Exposition*, Chicago, Illinois, 2006-650.
7. Moe, Gary, *Using Interactive Assessment Tools in the Classroom, Proceedings of the 2006 ASEE Annual Conference and Exposition*, Chicago, Illinois, 2006-2674.
8. Oberg, E., Jones, F. D., Horton, H. L., Ryffel, H.H., *Machinery's Handbook, 27th Edition*, Industrial Press Inc., New York, 2004.