

# **AC 2007-2538: INTEGRATING BIOMEMS AND BIOMEDICAL MICROSYSTEMS INTO ELECTRICAL ENGINEERING EDUCATION: A THREE-YEAR PILOT STUDY**

## **Ian Papautsky, University of Cincinnati**

IAN PAPAUTSKY received his Ph.D. in bioengineering from the University of Utah in 1999. He is currently a tenured Associate Professor of in the Department of Electrical and Computer Engineering at the University of Cincinnati. His research and teaching interests include application of MEMS and microfluidics to biology and medicine.

## **Erik Peterson, University of Cincinnati**

ERIK T. K. PETERSON received his M.S. in electrical engineering from the University of Cincinnati in 2006, and is currently pursuing his Ph.D. His research interests include microfluidics and MEMS devices for chemical and biological assays. He was the teaching assistant for the Biomedical Microsystems course discussed in this paper.

# **Integrating BioMEMS and Biomedical Microsystems into Electrical Engineering Education: A Three-Year Pilot Study**

## **Abstract**

Micromachining or microelectromechanical systems (MEMS) technologies are considered an enabling technology having revolutionary impact on many areas of science and engineering. MEMS technologies are now being applied to health monitoring, diagnosis and therapeutic applications, which are frequently referred to as BioMEMS or Biomedical Microsystems. Biomedical Microsystems research includes biological, biomedical, biochemical, and pharmaceutical analysis and synthesis using MEMS-based microsensors and microsystems. At the University of Cincinnati the state-of-the-art emerging MEMS and BioMEMS research was integrated within the graduate and undergraduate electrical engineering curricula. For the past three years a novel course *Introduction to Biomedical Microsystems* was offered. In these first three course offerings, enrollment has spread beyond the initial target audience of the Department of Electrical and Computer Engineering, and now includes students from mechanical engineering, environmental engineering, computer engineering, and biomedical engineering. Course evaluations over the past three years suggest that the course was successful for a number of reasons. The use of research articles to supplement lecture materials worked effectively, providing undergraduate students with a real world perspective. Reading assignments, discussions of research papers, and short quizzes at the beginning of lectures were used to test understanding of concepts. This was also done to ensure that students were not overwhelmed by the multidisciplinary material or the course pace. The results of the three-year pilot program are encouraging, and suggest that the approaches followed in this course could be adapted to introduce engineering students to advanced multidisciplinary research topics from many fields of science and engineering.

## **Teaching MEMS at the University of Cincinnati**

As we enter the 21st century, microelectromechanical systems (MEMS) have had a revolutionary impact on many areas of science and engineering. The application of MEMS technologies in research has already increased the performance of conventional methods in microorganism detection in environmental monitoring, drug discovery in the pharmaceutical industry, and clinical diagnostics. More importantly, it is enabling access to new information and applications on the molecular level.<sup>1</sup> The conceptual paper by Manz *et al.*<sup>2</sup> triggered an avalanche of developments and discoveries, which led to an exponential growth of the field.<sup>3,4</sup>

MEMS technologies are now being applied to health monitoring, diagnosis and therapeutic applications, which are frequently referred to as BioMEMS or Biomedical Microsystems. Biomedical Microsystems research includes biological, biomedical, biochemical, and pharmaceutical analysis and synthesis using MEMS-based microsensors and microsystems. Such devices and systems, having microscale dimensions, tend to behave differently than their macroscale counterparts. The unfamiliar physics involved can require modeling and specialized training. Dozens of universities across the country have recently recruited faculty in the field of

BioMEMS. These initiatives have brought the excitement of BioMEMS research to many graduate and research programs in electrical and mechanical engineering.

While the BioMEMS technologies have dramatically altered biomedical, pharmaceutical, and environmental research, they are yet to be successfully transferred to the undergraduate curricula. One of the key reasons for this is the interdisciplinary nature of BioMEMS. General MEMS curriculum development relies heavily on traditional material science, electrical engineering and mechanical engineering coursework.<sup>5,6</sup> However, BioMEMS curriculum requires additional background in biology and chemistry. Because of the interdisciplinary nature of BioMEMS and the background needed to study (and work) in this area, BioMEMS courses have traditionally been offered at the graduate level only and often require prerequisites not normally included in a typical electrical engineering curriculum.

We have found that many electrical engineering students at the University of Cincinnati have not participated in a biology course since their sophomore or junior year in high school. Thus, although our ABET accredited program provides adequate emphasis on chemistry, physics, and mathematics, we find that our students lack an appreciation for and understanding of the basic principles of biology. This condition of biology education for engineers may not be unique to the University of Cincinnati. Engineering students often do not have sufficient exposure to college-level biology, and engineering programs across the country need to reevaluate the emphasis placed upon chemistry and physics as part of ABET accreditation. We believe that biology should be emphasized in the electrical engineering curriculum to the same degree as chemistry and physics.

At the University of Cincinnati, a series of MEMS and BioMEMS courses has been developed over the past several years (Figure 1). The only prerequisite in the first class of each sequence are graduate or senior standing. Each of the courses provides depth in both theoretical and practical topics. Typical enrollment in these courses ranges from approximately 12 students in the graduate courses (700-level and above) to approximately 25 students in the dual-level

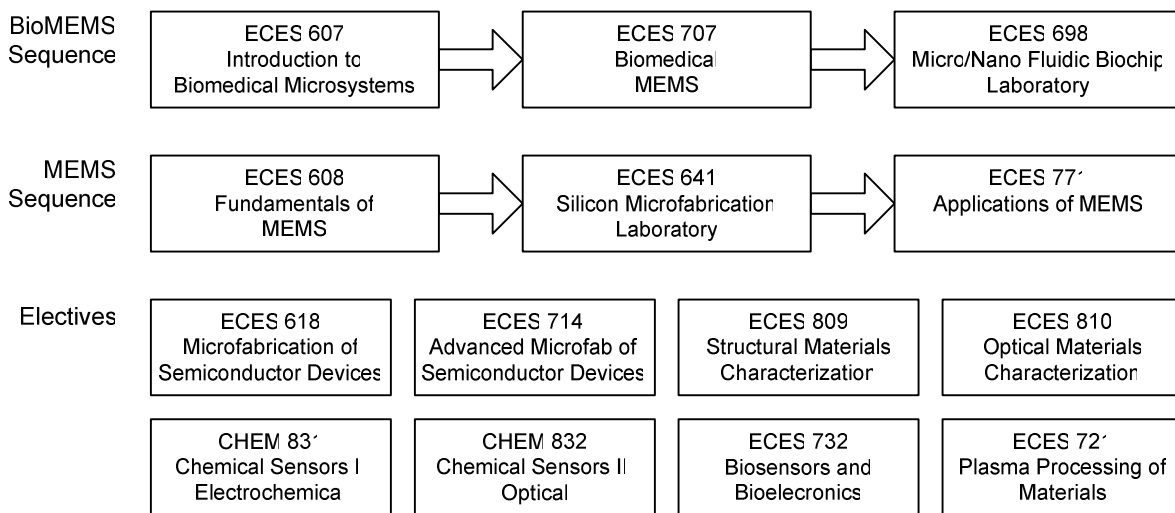

**Figure 1.** MEMS and BioMEMS courses offered at University of Cincinnati.

courses (600-level).

To expose undergraduate seniors and first-year graduate students to the emerging area of Biomedical Microsystems, a course entitled *ECES607: Introduction to Biomedical Microsystems* was introduced. The course is the first in a sequence of three courses focused on applications of MEMS and microsensors in biology, medicine, and environmental engineering. This course is the focus of this paper. The second course in the sequence provides a deeper coverage of the BioMEMS topics, with focus on lab-on-a-chip devices, biocompatibility, and cell engineering, and includes a brief in-depth review of relevant biological topics. The third course in the sequence is a new laboratory focused on design, fabrication, and characterization of microfluidic biochips, introduced in spring 2006 with support from the National Science Foundation.

Many undergraduate and most of the graduate students take the “BioMEMS sequence” concurrently with the “MEMS sequence,” which includes courses focused on principles of microfabrication and microsystem design. Thus, for most students, the *ECES607: Introduction to Biomedical Microsystems* course is not only the first exposure to BioMEMS, but also to MEMS.

### **The “Introduction to Biomedical Microsystems” Course**

The objective of the course is to expose students to biomedical microsystems and to teach them fundamental principles of MEMS applications in biology and medicine. Topics covered include BioMEMS fabrication, microsensors for medical applications, biochips and lab-on-a-chip (LOC) devices, microfluidics, biosensors, material biocompatibility, and cell/tissue engineering. The course was designed to be a ten-week long, three-credit-hour course consisting of twenty 75 min lectures. As a 600-level course, it was dual-level; intended for the undergraduate seniors and first year graduate students in the Electrical Engineering program. Details of the course format and content have been discussed previously.<sup>7,8</sup> The course had no prerequisites other than senior class standing. Further, no background in integrated circuit fabrication, MEMS, biomedical instrumentation, or any other specialized area was assumed or required. This permitted a diverse class makeup that presented some challenges.

The course instructor’s background is in the area of bioengineering. His current research focuses on developing and utilizing nano/micro fabrication techniques (MEMS) and nano/micro fluidics to study and solve current medical and environmental health problems. The teaching assistant for the course was an advanced Ph.D. student in the instructor’s laboratory with background in biomechanics. Thus, the instructor and teaching assistant were uniquely qualified to introduce the topic of BioMEMS and biomedical microsystems to electrical engineers.

For the purposes of teaching this course, the subject of Biomedical Microsystems was broken down in two categories. The first category of BioMEMS devices included MEMS devices that had a biological application. An example of such a device is a pressure sensor used for measurement of blood pressure. Most MEMS devices that have general applications with only slight potential modification for use in a biological environment were not discussed in the class, since it was assumed they would be covered in a general MEMS course (*e.g.*, ECES608 or ECES771). Multi-purpose devices such as microanalysis systems that could be used for purely

chemical and environmental applications in addition to biological and medical applications were closely covered in the class. These devices often require specific properties or modification to be used in biological applications.

The second category of biomedical microsystems was much more biologically oriented and included only devices that were specifically designed to operate in the presence of biological media or incorporated a biological component. One example of such a device would be microfluidic channels for cell culture, which do not include any biological components but are specifically designed to interact with biological tissues and fluids. Another example would be an enzyme-based biosensor (ENFET), such as a glucose sensor. While the biosensor is based on a chemical ion-selective sensor (ISFET), the enzyme component would require unique design methods and would make the device an example of a biomedical microsystem.

Topics and their sequence were selected with three criteria in mind. The first criterion was to introduce students to MEMS fabrication. Thus, the first two weeks of the course focused on introducing the major techniques and approaches in MEMS fabrication, but with focus on biomedical applications. During that time, students learned how to fabricate two fundamental structures that were revisited throughout the rest of the course: a suspended diaphragm and a sealed microchannel. The diaphragm was revisited later in the course when discussing pressure microsensors and their clinical applications, and again when discussing microfluidic valves and pumps. Microchannels were revisited when discussing microfluidic, micromixers, bio/chemical sensors, and biochips. The discussion of MEMS fabrication, and specifically the two fundamental systems, provided students with a foundation of common ground.

The second criterion was not to overwhelm the electrical engineering students by the breadth of the interdisciplinary topics encompassed in BioMEMS. By senior year, the students are knowledgeable in electrical engineering topics, but have few courses outside the department. Also, as already discussed, few students had exposure to biology. Thus, course topics were chosen to build on the students' electrical engineering background earlier in the course and to guide them in the directions of the more biologically intense nature of BioMEMS towards the end of the course. Based on this criterion, discussion of a conventional pressure microsensor was introduced early in the course and transitioned to biosensors and cell engineering toward the end of the course.

The third and final criterion was to give students equal exposure to the theoretical principles and their bio/medical applications. For example, after introducing fundamentals of pressure microsensor function, application to intravascular pressure measurements was discussed. This theme of "from theory to application" was carried out throughout the course.

At the present time, the potential textbooks for a course in biomedical microsystems are few, and none are specifically written for the undergraduate level. We chose an existing MEMS textbook by Hsu (2002), entitled *MEMS and Microsystems: Design and Manufacture*. The text was selected for three key reasons. First, this is one of the few texts aimed at the undergraduate level. As such, it includes worked examples in every chapter. Worked examples are critical for a good undergraduate textbook as supported by research in the area of learning which shows that using worked examples results in more effective learning by reducing cognitive load.<sup>9,10</sup> Second, the

text provides multiple-choice questions and sample problems at the end of each chapter. These sample problems and questions (*i.e.*, learning by doing) allow students to gain deeper understanding of the material outside of the classroom and to prepare for exams. Finally, the text discusses microsystems design as well as MEMS fundamentals, including microfabrication, mechanics, microfluidics, and thermodynamics. Although these topics were not covered in detail in this course and are rather discussed in another course (ECES608), having these materials in the text provided a good reference, particularly to those not taking the ECES608 course.

To supplement the textbook, students read journal articles related to the topics covered in class. The strategy was to expose students to the state-of-the-art developments and give them a flavor of what happens in the research environment. The first article was a review, but by the end of the course, students were reading current research articles. The positive outcome of the exposure to research articles was more grounding in the course material, deeper understanding of real-world applications, as well as lively in-class discussions. Due to the multidisciplinary makeup of the students in the class, interesting discussions were fueled by the variability of their backgrounds (in terms of discipline and level of education) and therefore, variety of ideas.

During the three-year pilot test of the course, 77 undergraduate and graduate students have participated. The enrollment is summarized in Table 1. During this time, the course enrollment represented all three programs within the Department of Electrical and Computer Engineering, namely electrical engineering, computer engineering, and computer science, Department of Mechanical Engineering, Department of Biomedical Engineering, and a student from the international exchange program. Thus, the enrollment in the course has grown beyond the instructor's original electrical engineering target audience to include multidisciplinary participation.

When the course was first advertised in 2004, a large number of students expressed interest. However, since the initial offering, undergraduate student participation has declined while the graduate participation increased slightly. In part, this is reflective of the declining trend in undergraduate enrollment in the electrical engineering program at University of Cincinnati. Another plausible reason is that the level of material presented in the course and the overall scope of work may be more reflective of a graduate course. Nevertheless, the course enrollment remains consistent with the average department enrollment in dual-level courses. Overall, the

**Table 1.** Summary of course enrollment for the 2004-2005 through 2006-2007 academic years.

Enrollment	Academic year		
	2004-2005	2005-2006	2006-2007
Graduate	11	12	15
Undergraduate	23	10	6
Total	34	22	21

course met the instructor's expectations with regards to enrollment by maintaining representation from both graduate and undergraduate students and growing beyond its original electrical engineering target to include multidisciplinary participation.

## Results of Course Evaluations

The first offering of the course in 2004 was a considerable success. At the end of the course, students were provided with an anonymous course evaluation form that asked a number of open ended questions. Thirty of 34 students enrolled in the course responded to the evaluation on the last day of the course. The subsequent offerings of the course were also successful. Nineteen of the 22 students enrolled in the course in 2005 responded to the evaluation on the last day of the course. In 2006, 16 of the 21 students enrolled responded. Table 2 summarizes the results of students' responses to questions regarding demographics, programs and fields of study, and coursework outside electrical engineering.

Most of the students indicated that they had not participated in any formal training in biology or mechanical engineering. Yet these topics are critical to appreciation and understanding of the multidisciplinary subject of biomedical microsystems. Although the undergraduate electrical engineering program at University of Cincinnati provides adequate emphasis on chemistry, physics, and mathematics, students often do not have sufficient exposure to college-level biology. We believe the electrical engineering curriculum should place as much focus on biology as it places on chemistry and physics.

In addition to the demographic questions, surveys also asked several open-ended questions. A detailed discussion of these results will be presented elsewhere,<sup>11</sup> but responses to key questions are summarized below.

In response to the question "Where the objectives of the course met?" students responded:

- 2004: *Yes, practical examples were used throughout the course and we could see how the concepts were involved in real world*
- 2004: *Yes, the goals were met, but specific biology material was not as complete as it could be*
- 2005: *I believe the goals of the course were accomplished. We were introduced to various biomedical microsystems and developed an understating of their applications in biology and medicine*
- 2005: *Yes, we gained a clear insight into the applications of MEMS in biology and medicine*
- 2006: *Yes, but I think we dove too quickly into some areas, like DNA, when no one had too much background in it.*
- 2006: *Yes. Because we could see [many] types of microsystems, how to build them and where we can apply that [knowledge]. ... [we] also saw biological, chemical, and medical issues [relevant to] microsystems.*
- 2006: *Yes, but the pace was too fast.*

**Table 2.** Summary of students' responses to questions regarding demographics, program and field of study, and coursework outside electrical engineering.

<i>Demographics</i>					
<i>Sex</i>	<i>N = 65</i>	<i>%</i>	<i>Age</i>	<i>N = 65</i>	<i>%</i>
Male	55	84.6%	<23	29	44.6%
Female	10	15.4%	23-26	27	41.5%
			27-30	4	6.2%
			30+	5	7.7%

<i>Current degree</i>					
<i>Program</i>	<i>N = 65</i>	<i>%</i>	<i>Field</i>	<i>N = 66</i>	<i>%</i>
Undergraduate	35	53.8%	Electrical Eng.	55	83.3%
Graduate	30	46.2%	Computer Eng.	6	9.1%
			Other	5	7.6%

<i>Highest degree expected</i>					
<i>Program</i>	<i>N = 65</i>	<i>%</i>	<i>Field</i>	<i>N = 66</i>	<i>%</i>
BS	19	29.2%	Electrical Eng.	51	77.3%
MS	29	44.6%	Computer Eng.	2	3.0%
PhD	17	26.2%	Other	12	18.2%

<i>Number of previous courses in</i>					
<i>Biology</i>	<i>N = 64</i>	<i>%</i>	<i>Mechanical eng.</i>	<i>N = 63</i>	<i>%</i>
<1	44	68.8%	<1	45	71.4%
<2	11	17.2%	<2	7	11.1%
<4	6	9.4%	<4	6	9.5%
<6	0	0%	<6	2	3.2%
8+	2	3.1%	8+	2	3.2%

To the question "What was the best aspect of the course?" students responded:

- 2004: *The material presented was current and on the cutting edge*
- 2004: *Reading journal articles for homework*
- 2004: *The real world examples used throughout the class; it helped to reinforce the material*
- 2005: *Reading research articles provided a new prospective on and more in-depth understanding of fabrication methods*
- 2005: *Very interesting material; I took the course to see if it was something I would like to pursue; I enjoyed the topics covered and plan on taking more*
- 2005: *I gained an understating of the developing technology; good exposure to new technologies in MEMS*

- 2006: *The best aspect of the course was the research article discussions. It kept us informed of research and let us see applications of concepts learned in class.*
- 2006: *I really liked the topics ... I can see the need for this in many real world applications and how it can help improve life.*
- 2006: *It's multidisciplinary approach and the breadth of topics covered.*

In response to the question “What would you suggest improving?” students responded:

- 2004: *Too much information in such a short amount of time; more explanation of fewer topics instead*
- 2004: *The amount of information covered was too great; cutting some of the course material and covering it in another class in MEMS would have helped in some places where we were rushed*
- 2005: *Too much time was spent on fundamentals of fabrication; more emphasis should be placed on applications*
- 2005: *Microfluidics description – I had never seen any fluid dynamics and the textbook was not very helpful*
- 2005: *Reading more articles appropriate to the progress of the course*
- 2005: *More details in biological area*
- 2006: *The course is very good, but it would be better if it was divided into two courses because it has a lot of material.*

The representative responses to the open-ended questions support the conclusion that the course has been a success. Both undergraduate and graduate students indicated that they appreciated all of the effort put into providing an opportunity to see “state-of-the-art” research in the classroom. As identified in the first course offering, the two greatest challenges to introducing biomedical microsystems to electrical engineering students are: successfully integrating research topics into the classroom, and developing appropriate background to introduce students to the principles of biology. We addressed the first challenge by using real world examples throughout the course to reinforce the theoretical lecture material, and supplementing lectures with current research papers. The second challenge is the more difficult one. We attempted to address it by providing brief review of the relevant biological and chemical topics during the appropriate lectures, and dedicating some lectures in the beginning of the course to the discussion of microfabrication. In the second offering of the course, quizzes were introduced in the beginning of some lectures. The students commented that the quizzes provided direction by highlighting key concepts and critical vocabulary. Quizzes also led to more engaging discussions in the classroom.

## **Conclusions**

There is a clear need to convey the necessity for multidisciplinary education early in the engineering curriculum, so that students do not wait until their senior year to take courses in biology. A good BioMEMS textbook that integrates fundamentals with applications would be tremendously helpful to addressing the challenge of teaching the multidisciplinary topic of biomedical microsystems to engineers. Overall, the results of this three-year pilot program are encouraging, and suggest that the approaches followed in this course could be adapted to

introduce engineering students to advanced multidisciplinary research topics from many fields of science and engineering.

## Acknowledgements

The authors would like to thank the Department of Electrical and Computer Engineering for supporting these efforts to develop and improve a new course to introduce biomedical microsystems to electrical engineers.

## References

1. A. Manz and H. Becker, *Microsystem Technology in Chemistry and Life Sciences* (Springer-Verlag, 1999).
2. A. Manz, N. Graber, and H. M. Widmer, *Sensors Actuators B* **1**, 244-248 (1990).
3. S. Latta, *Scientist* **11**, 1-7 (1997).
4. T. Laurell, J. Nilsson, K. F. Jensen, D. J. Harrison, and P. Jorg (eds.) *Proc. Micro Total Analysis Systems 2004* (Elsevier, 2004).
5. L. Lin, *IEEE Trans. Education* **44**, 61-66 (2001).
6. T. Ameel, B. Gale, and I. Harvey, "A Three-semester Interdisciplinary Educational Program in Microsystems Engineering," *Proc. ASEE Conference*, Salt Lake City, UT, June 20-23, 2004.
7. I. Papautsky and E. T. K. Peterson, "Introducing biomedical microsystems into the electrical engineering curriculum," *Proc. ASEE Conference*, Portland, OR, June 12-15, 2005, CD-ROM, 8 pages.
8. I. Papautsky and E. T. K. Peterson, "A Biomedical Microsystems Course for Electrical Engineers," *Proc. ASEE Conference*, Chicago, IL, June 13-16, 2006, CD-ROM, 7 pages.
9. J. Sweller and G. Cooper, *Cognition and Instruction* **2**, 59-89 (1985).
10. G. Cooper and J. Sweller, *J. Educational Psychology* **79**, 347-362 (1987).
11. I. Papautsky and E. T. K. Peterson, "An introductory course to biomedical microsystems for undergraduates," *Biomedical Microdevices* (in press).