

AC 2007-337: CLARIFICATIONS OF RULE 2 IN TEACHING GEOMETRIC DIMENSIONING AND TOLERANCING

Cheng Lin, Old Dominion University

Alok Verma, Old Dominion University

CLARIFICATIONS OF RULE 2 IN TEACHING GEOMETRIC DIMENSIONING AND TOLERANCING

Abstract

Geometric dimensioning and tolerancing is a symbolic language used on engineering drawings and computer generated three-dimensional solid models for explicitly describing nominal geometry and its allowable variation. Application cases using the concept of Rule 2 in the Geometric Dimensioning and Tolerancing (GD&T) are presented. The rule affects all fourteen geometric characteristics. Depending on the nature and location where each feature control frame is specified, interpretation on the applicability of Rule 2 is quite inconsistent. This paper focuses on identifying the characteristics of a feature control frame to remove this inconsistency. A table is created to clarify the confusions for students or designers, who can use it to justify their applications in the GD&T design.

1. Introduction

Geometric Dimensioning and Tolerancing (GD&T) has been around in one form or another since World War II. The need to define ever more complex part geometry and the need to guarantee interchangeability of parts has contributed to its widespread use. Today, it can be found in nearly all manufacturing industries, from the very small geometry found in Integrated Circuits to the very large geometry found on rockets, the Space Shuttle and the International Space Station.

It has found its greatest application in mass production, where interchangeability of blindly selected parts is essential. Just-in-time manufacturing increases the demand for parts that absolutely must fit at assembly, as it is much less likely today to have spare parts waiting in the warehouse. Parts simply must fit together at assembly.

In the engineering drawing design, GD&T is a means of specifying engineering design and drawing requirements with respect to actual “function” and “relationship” of part features. If the technique of GD&T is properly applied, it will ensure the most economical and effective production of these features, and also provides a uniform integration and interpretation of design, production, and inspection for a part^{1,2,3,4,5}. In the United States, the governing rules of using GD&T are based on ASME 14.5M – 1994⁶, “Dimensioning and Tolerancing”.

As shown in the first column of Table 1, there are five categories of geometric characteristics in the GD&T¹: (1) Form, (2) Orientation, (3) Profile, (4) Runout, and (5) Location Tolerances. Form Tolerances include Flatness, Straightness, Circularity, and Cylindricity; Profile Tolerances include Profile of a Line and Profile of a Surface; Orientation Tolerances include Perpendicularity, Angularity, and Parallelism; Runout

Tolerances include Circular Runout and Total Runout; Location Tolerances include Position, Concentricity, and Symmetry.

The third column of the table shows the symbols of each geometric characteristic, and the fourth column provides the characteristics of each geometric tolerance with a datum or datums. For example, an individual feature (i.e. one of the Form Tolerances) is compared to a perfect geometric counterpart of itself. Therefore, no datum is needed. For related features (i.e. Orientation and Location Tolerances), the tolerance is related to a datum or datums. It's interesting to notice that the Profile Tolerances, based on their characteristics, can be either individual or related features. The geometric tolerances can be applied to three material conditions, which will be discussed in the following paragraphs.

Types	Characteristic	Symbols	Feature with Datum
Form	Flatness		Individual
	Straightness		
	Circularity		
	Cylindricity		
Profile	Profile of a Line		Individual or Related
	Profile of a Surface		
Orientation	Perpendicularity		Related
	Angularity		
	Parallelism		
Runout	Circular Runout		
	Total Runout		
Location	Position		
	Concentricity		
	Symmetry		

Table 1: GD&T categories, characteristics, symbols, and feature with datum.

There are two basic rules available in the GD&T: Rule 1 and Rule 2. To be able to fully discuss Rule 2, the following terms must be defined first: feature of size, material conditions, and two basic rules.

2. Feature of Size, Material Conditions, and Two Basic Rules

Based on the design and manufacturing needs, geometric tolerances can be specified with different material conditions, which include Maximum Material Condition (MMC), Least Material Condition (LMC), and Regardless of Feature Size (RFS). Before the material conditions are introduced, the term of Feature of Size (FOS) must be defined first. This is because that a geometric characteristic cannot be applied with a non-FOS.

2.1 Feature of Size (FOS)

According to ASME 14.5M⁶, Feature of Size is defined as:

“One cylindrical or spherical surface, or a set of two opposed elements or opposed parallel surfaces, associated with a size dimension.”

Figure 1 shows the top and front projection views of a part with dimensioning. Based on the definition of FOS, Dimensions A, B, D, H, K, and J are feature of sizes, while Dimensions E, F, G, and I are non-FOS.

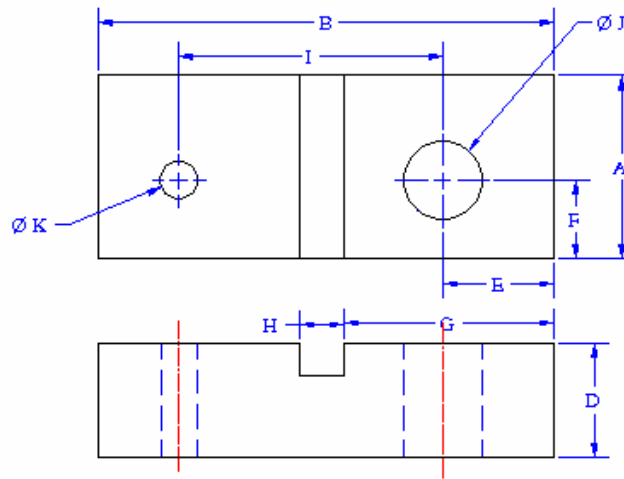

Figure 1: An example for feature of size.

2.2 Maximum Material Condition (MMC)

To indicate that a geometric tolerance is specified with MMC, a symbol m is added to either a geometric characteristic or a datum. Maximum Material Condition is particularly defined as having the maximum solid volume for a part. Therefore, for internal parts (i.e. holes or grooves), MMC is at its minimum FOS. For external parts (i.e. pins or studs), MMC is at its maximum FOS. When a geometric characteristic is specified with MMC, the geometric tolerance may have a bonus tolerance when its FOS is approaching to its Least Material Condition (LMC). Figure 2 shows a design drawing using an MMC Position Tolerance with Datum A as the center axis of the Hole $\phi 0.8$. From the table shown in this figure, if the diameter of a part is measured at 1.02, which is the MMC, there is no bonus tolerance and the Position Tolerance remains at 0.05. However, when the diameter is measured at 0.98, which is the LMC, the bonus tolerance is equal to 0.04. Therefore, the total Position Tolerance in this case increases to 0.09. Because of the bonus tolerances, application of MMC can be easily found in most GD&T design drawings.

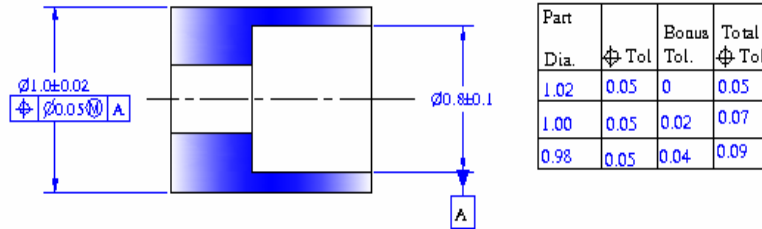

Figure 2: A design drawing using MMC Position Tolerance.

2.3 Least Material Condition (LMC)

To indicate that a geometric tolerance is specified with LMC, a symbol \perp is added to a geometric characteristic. Least Material Condition is particularly defined as having the least solid volume for a part. Therefore, for internal parts, LMC is at its maximum FOS. For external parts, LMC is at its minimum FOS. When a geometric tolerance is specified with LMC, the geometric tolerance may have a bonus tolerance when its FOS is approaching to its MMC. Figure 3 shows a design drawing using an LMC Position Tolerance with Datum A, which is the center axis of the Hole $\varnothing 0.8$. From the table shown in this figure, when the diameter of a part is measured at 1.02, which is the MMC, there is a bonus tolerance and the total Position Tolerance increases to 0.09. However, when the diameter of a part is measured at 0.98, which is the LMC, there is no bonus tolerance. LMC is particularly applied to guarantee a larger minimum thickness in a thin part than MMC.

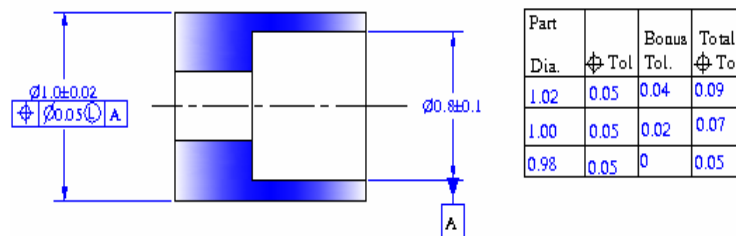

Figure 3: A design drawing using LMC Position Tolerance.

2.4 Regardless of Feature Size (RFS)

Unlike MMC and LMC, Regardless of Feature Size gives no additional geometric tolerance. The concept of RFS has been used prior to the introduction of MMC and LMC principles. Figure 4 shows a design drawing using an RFS Position Tolerance. Since there is no modifier added to the Position Tolerance, according to Rule 2⁶, the Position Tolerance is an RFS. From the table shown in this figure, the Position Tolerance remains the same regardless the variations on the FOS.

In the GD&T, there are two basic rules. As Rule 1 is clearly stated, it will only be briefly mentioned in the follow paragraph. Clarification of Rule 2 will be more thoroughly discussed.

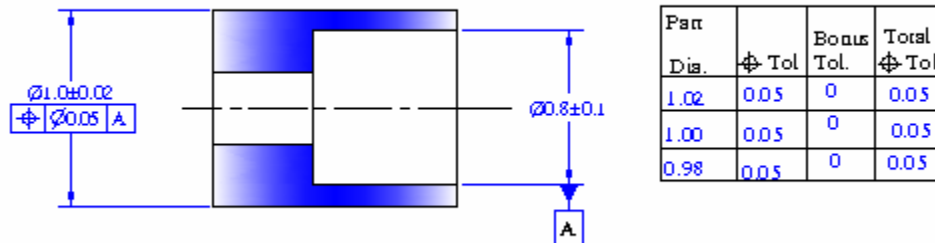

Figure 4: A design drawing using RFS Position Tolerance: no bonus tolerance.

2.5 Rule 1

According to ASME14.5M^{1,6,7}, Rule 1 states:

“Where only a tolerance of size is specified, the limits of size of an individual feature prescribe the extent to which variations in its form – as well as in its size- are allowed.”

This definition includes two main components: (1) the envelope-size principle and (2) the Form Tolerance allowed when a FOS departs from MMC. For example, Figure 5 shows the diameter of a shaft in an engineering drawing. Figure 6 shows the envelope-size principle, which states that the FOS is applicable not only to the size at each cross section, but also to the whole length of the feature. Figure 7 shows that, when the FOS departs from its MMC, a Form Tolerance will be allowed. Therefore, when the FOS is at its MMC, the part must have a perfect form.

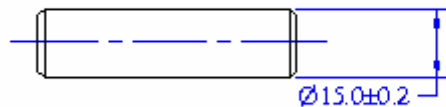

Figure 5: An engineering drawing.

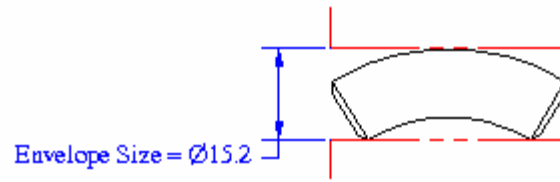

Figure 6: The envelope-size principle.

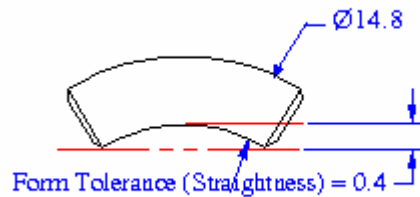

Figure 7: An allowable Form Tolerance for a part when its diameter departs from MMC.

2.6 Rule 2

According to ASME14.5M^{1,6,7}, Rule 2 states:

“For all applicable geometric tolerances, Regardless of Feature of Size (RFS) applies with respect to the individual tolerance, datum reference, or both, where no modifying symbol is specified. Maximum Material Condition m , or Least Material Condition l , must be specified on drawing where it is required.”

The rule can be applied to the design drawing shown in Figure 4. Due to the nature of the control, RFS can be applicable at most of geometric characteristics except at three Form Tolerances: Flatness, Circularity, and Cylindricity. While Rule 2 seems clear and simple, several geometric characteristics without m or l are still non RFS. These exceptions cause confusions to the students when taking this class.

3. Cases in Which Rule 2 Applies

There are two cases in which Rule 2 is applicable. The first case is when a geometric characteristic is applied with an FOS, and the second case is when a geometric characteristic is applied with a feature.

3.1. RFS when Geometric Characteristics applied with FOS

Geometric characteristics which are allowed to specify with FOS are Straightness, Perpendicularity, Parallelism, Angularity, Position, Circular Runout, Total Runout, Concentricity, and Symmetry, are RFS.

3.1.1 RFS with Straightness

Figure 8 shows that a Straightness Tolerance is specified with an FOS. The Straightness is used to control the central axis of the shaft. As shown from the table, the Straightness Tolerance remains the same regardless the change on the FOS of the diameter. Therefore, this is an RFS. In the Form Tolerances, RFS is only applicable to Straightness.

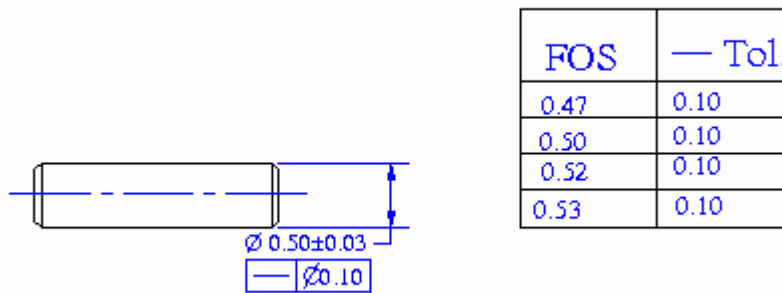

Figure 8: RFS Straightness control on the central axis of a shaft

3.1.2. RFS with Orientation Tolerances

Figure 9 shows that a Perpendicularity Tolerance is specified with an FOS. Similar to the RFS with Straightness, the Perpendicularity is used to control the central axis of the hole. As shown from the table, the Perpendicularity Tolerance remains the same regardless the change on the FOS of the diameter. Therefore, this is an RFS. The same situation can be applied to other Orientation Tolerances.

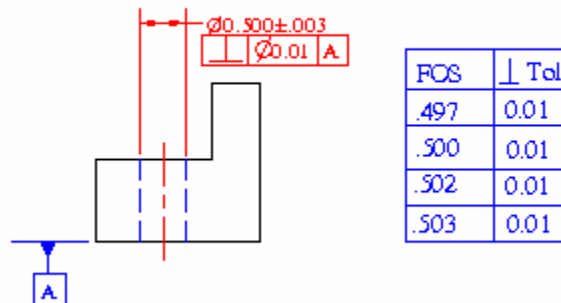

Figure 9: RFS with Perpendicularity.

3.1.3. RFS with Location Tolerances

As given in Table 1, Location Tolerances includes Position, Concentricity, and Symmetry Tolerances. Figure 10 shows that a Position Tolerance with RFS. The Position Tolerance zone of $\phi 0.015$ is used to control the central location of the hole. The boxed dimensions in this drawing are called basic dimensions, which can be described as the theoretically exact dimensions. As shown from the table, the Position Tolerance remains the same regardless the variations on the FOS of the diameter. The same rule can be applied to other Position Tolerances, such as Concentricity and Symmetry.

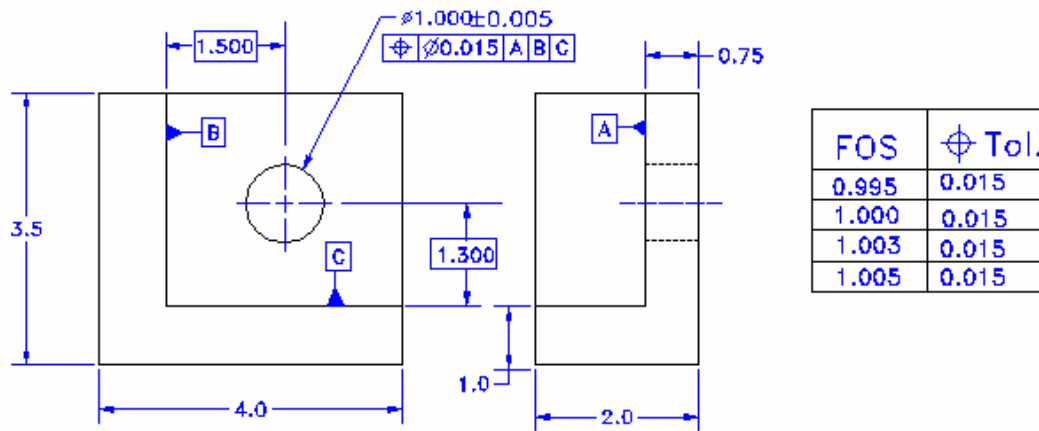

Figure 10: RFS with Position Tolerance.

From the examples shown above, when a geometric characteristic is specified with an FOS, the tolerance will be an RFS, with only one exception when a Circularity Tolerance is applied to a sphere. This exception will be discussed in the next paragraph.

3.1.4 RFS with Runout - FOS

Figure 11 shows a Runout Tolerance with RFS. The tolerance zone of 0.015" is used to control the Total Runout on the outer surface of $\phi 4.500$ ". Therefore, when compared to tolerance zone in Figure 10, there is no ϕ in front of 0.015". The datum axis is at the center axis of $\phi 2.000$ ". As shown from the table, the Total Runout remains the same regardless the variations on the FOS of the diameter.

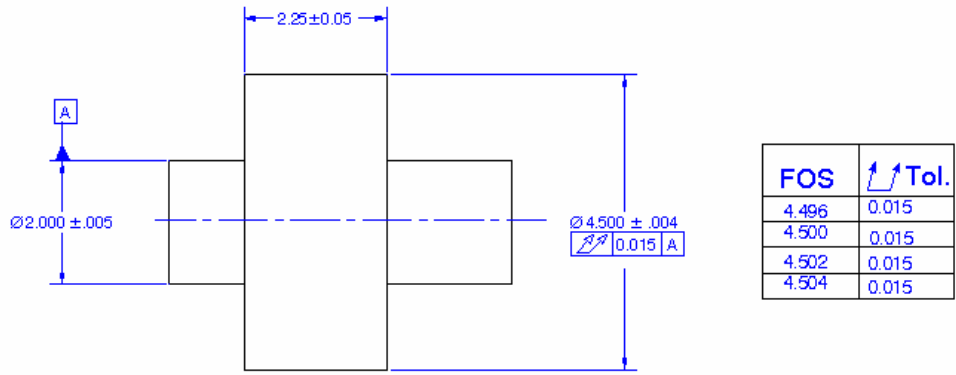

Figure 11: RFS with Runout Tolerance - FOS.

3.2 RFS with Runout when applied with a feature

Apart from the examples given in Section 3.1, there is only one RFS example when the geometric characteristic is applied with a feature. The geometric characteristic is a Runout control, which is shown in Figure 12. The circular runout of 0.06 is to control the wobble of the Surface B, and is measured when the surface is rotated around the datum axis A. Based on the nature of the runout measurement, the Circular Runout remains the same regardless the variations on the FOS (2.25”). Therefore, this is also an RFS.

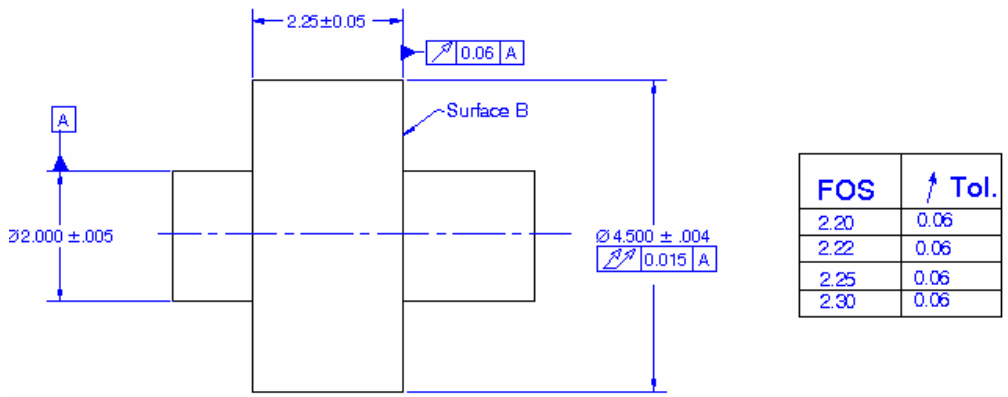

Figure 12: RFS with Runout Tolerance - Feature.

4. Exceptions of Rule 2

Exceptions of Rule 2 are found in Form and Profile Tolerances. In these applications, although the geometric characteristics do not use m or L, they are still not considered as RFS.

4.1. Exceptions When a Geometric Characteristic Is Applied to the Feature

With the only exception to the Runout Tolerance, when specifying a geometric characteristic with a feature, Rule 2 is always not applicable. The geometric tolerance must be a refinement of the feature of size. The reason is explained in the following paragraphs.

4.1.1. Exception to the Form Tolerances

Figure 13 shows a flatness control on a design drawing. The Flatness 0.002” is used to control the top surface. Unlike the geometric tolerance control in Figure 4 where the geometric tolerance (0.05”) can be larger than the tolerance on the FOS (0.04”), this geometric tolerance (0.002”) must be smaller than the FOS (0.10”) tolerance. In addition, Figure 8 also shows that the Flatness will have to be smaller than 0.002” when the FOS of a part is close to MMC. As shown in the table of this figure, if the FOS of a part is smaller than 1.753”, the Flatness is 0.002”. However, when the FOS is equal to 1.754”, the Flatness must be changed to 0.001”. This is because the flatness control is dominated by Rule 1. Therefore, the total envelope size of the part must be equal to 1.755”, which is MMC.

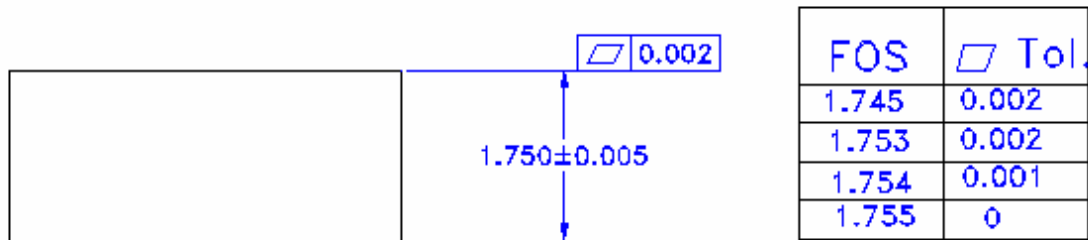

Figure 13: Non-RFS for Flatness control.

Similar to Flatness, Figure 14 shows a shaft with a Circularity control of 0.02”. The Circularity can only be applied to a feature, which, in this case, is the outer surface of the cylinder. Similar to the Flatness control, when the diameter of a part is larger than $\phi 0.51$ ”, the Circularity must be smaller than 0.02”. This is because that the envelope size must be always equal to 0.53”. Since the Circularity is affected by the FOS, it is not an RFS. The same situation can be applied to Cylindricity and Straightness by replacing the geometric characteristic of e with g or u in this figure.

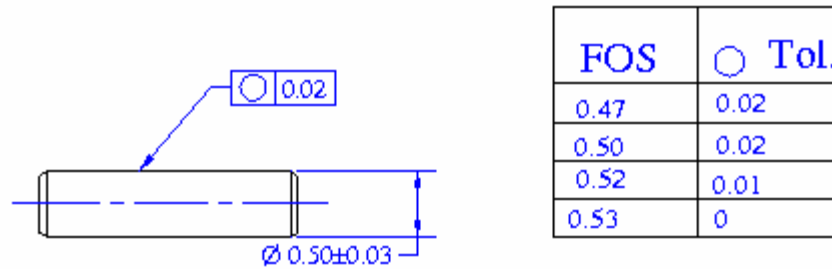

Figure 14: Non-RFS for Circularity.

4.1.2 Exception to Profile Tolerances

Figure 15 shows a Profile of Line control 0.005", which is applied on the outer arc surface of the part. Similar to the previous example, when the FOS of a part is larger than 2.045", the Profile Tolerance must be smaller than 0.005". Therefore, this is not an RFS either. The situation is the same as in the Profile of a Surface d.

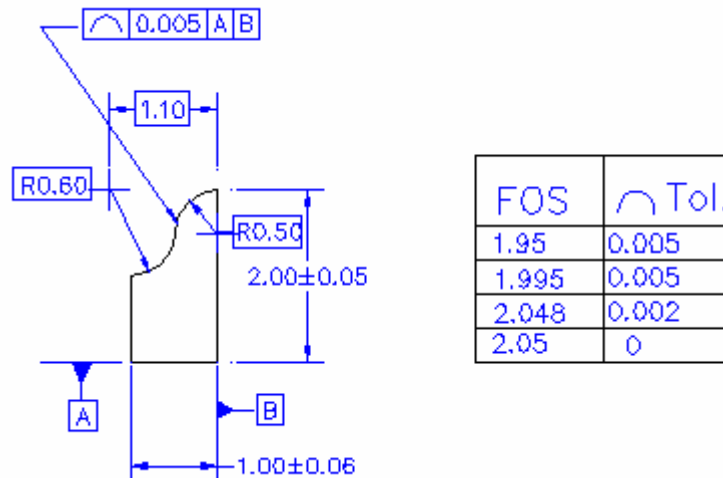

Figure 15: Non-RFS for Profile Tolerance.

4.2. An Exceptional Case When a Geometric Characteristic Is Applied to an FOS

Figure 16 shows the circularity control on a sphere. Since the tolerance control reference is to any cross section passing through a common center rather than to any cross section perpendicular to the axis of a cylinder, the Circularity Tolerance is applied with an FOS¹. Similar to the previous cases, this circularity control on the sphere is not an RFS.

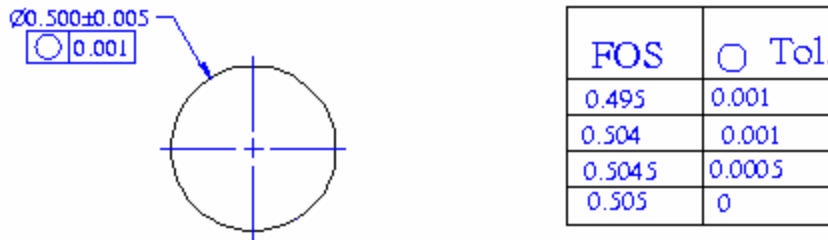

Figure 16: Non-RFS on Circularity when applied with an FOS.

5. Summary

This paper attempts to remove confusion associated with the application of rule 2. Based on the previous examples, Table 2 is created to list the applicability of Rule 2. The rules are based on the nature of each geometric characteristic during the design. Based on previous examples, Flatness, Cylindricity, and Profile Tolerances are not allowed to be specified with FOS. Therefore, Rule 2 is not applicable in these cases. Runout is the only exception that Rule 2 is applicable when the geometric characteristic is specified with a feature or feature of size. While the Circularity control on a sphere can be specified with FOS, its intended control is still on the outer surface; therefore, Rule 2 is not applicable in this case. The only exception (in the Form Tolerances) is the Straightness, which can be either specified with a feature or an FOS. If the Straightness is used to control the center axis, then Rule 2 is applicable. The same situation can be applied to the Orientation Tolerances. In most cases, if a geometric characteristic is specified with an FOS, Rule 2 is applicable, with the only exception on the circularity control of a sphere.

Types	Characteristic	Applicable with Feature	Applicable with FOS	Applicable with Rule 2
Form	Flatness	Y	N	N
	Straightness	Y	Y	N (Feature) Y (FOS)
	Circularity	Y	Y (only with sphere)	N
	Cylindricity	Y	N	N
Profile	Profile of a Line	Y	N	N
	Profile of a Surface	Y	N	N
Orientation	Perpendicularity	Y	Y	N (Feature) Y (FOS)
	Angularity	Y	Y	
	Parallelism	Y	Y	
Runout	Circular Runout	Y	Y	Y
	Total Runout	Y	Y	Y
Location	Position	Y	Y	Y
	Concentricity	N	Y	Y
	Symmetry	N	Y	Y

Table 2: Rule 2 table.

References:

1. L.W. Foster, "GEO-METRICS III", Prentice Hall, 1994.
2. ASME Y41.5M - 1994, "Dimensioning and Tolerancing", American Society of Mechanical Engineers, 1995.
3. R. Clark, "Bonus Tolerances for GD&T", Tooling and Production, v71, n2, Feb. 2005.
4. K. Rennels, "Current Methodologies for Geometric Dimensioning and Tolerancing", Electrical Insulation Conference and Electrical Manufacturing and Coil Winding Conference and Exhibition, 2003.
5. P. Chiabert, F. Lombardi, and M. Orlando, "Benefits of Geometric Dimensioning and Tolerancing", Journal of Materials Processing Technology, v 78, n 1-3, 1998.
6. ANSI Y14.5M, "Dimensioning and Tolerancing.", American Society of Mechanical Engineers, 1994.
7. A. Krulikowski, "FUNDAMENTALS OF GEOMETRIC DIMENSIONING AND TOLERANCING", Delmar, 1998.