

**AC 2007-508: INTRODUCING MATH SOFTWARE AND ELECTROMAGNETICS
SIMULATION SOFTWARE TO ENHANCE THE VECTOR FIELD
UNDERSTANDING IN EM CLASSES**

Tianxia Zhao, Indiana-Purdue University-Fort Wayne

Introducing Math Software and EM Software to Enhance the Vector Field Understanding in EM Classes

Abstract

Electromagnetics(EM) is a traditionally difficult subject for engineering students. The understanding of the field concepts requires a lot of advanced mathematical knowledge and analytical ability. This course is particularly important for understanding a lot of electrical phenomena.

The objective of this paper is to develop computer assisted materials to generate plots and animations for EM fields. Extensive examples are shown to help illustrate the concepts of static electric field and steady magnetic field, dynamic fields and radiation.

Introduction

Whereas the study of electromagnetics has been motivated primarily by military-defense applications, important applications in Electromagnetic Compatibility and Interference (EMC/EMI) study in high-speed communications and computing has attracted attention recently. Those applications will favorably impact the economic well-being as well as military security. The advancement of technology involve electromagnetic interference in high-speed circuit, EM guidance and radiation in communication systems, advanced medical equipment, and nanotechnology and the implementation of available electronics functions to optical frequencies. As a result, these renewed EM applications in all the engineering areas require better understanding and grasp of the electromagnetic field and waves concepts for the engineering students.

An introduction of EM static field is normally included in a sophomore level physics class. However the depth and coverage are rather limited. A junior level course in basic electromagnetics is normally in the core curriculum for students majored in electrical engineering. Electromagnetics is a difficult subject due to the requirement of advanced mathematical and analytical background. Students often find it discouraging and uninteresting. However, this course is particularly important for understanding a lot of electrical phenomena, from electronics circuit theory and communication system, to the operation of electromechanical systems.

To keep up with the advancements of EM technology, to help the students to understand the basic concepts in a more effective way, and to make the course more interesting, the current EM course at the engineering department at Indiana University-Purdue University Fort Wayne (IPFW) needs improvement. More computer simulation and visualization features will be introduced to help the students have better physical concepts understanding. In addition, radio frequency (RF) and microwave courses following the fundamental engineering electromagnetics course will be developed.

Course Curriculum at IPFW:

Currently, there is one EM course “Electric and Magnetic fields” (ECE 311) at IPFW. It introduces the fundamental physical concepts of static electric and steady magnetic fields, dynamic fields, Maxwell’s equations, wave propagation and transmission line. Vector calculus is extensively used in the course. The EM applications (electromagnetic waves, antenna and waveguide) are the basis for communication system. The prerequisite for the EM course is “Heat, Electricity and Optics” (PHYS 251), where the static fields are briefly discussed. The math courses “Multivariable calculus” and “Differential equations” (MA 261 and 363) are also required. Transmission line theory is the basis for the RF circuit impedance matching and passive circuit analysis. Out of the contents listed above, the students find the understanding of the vector space and fields the most difficult, let alone connecting the theories with the real engineering practice and phenomenon. So the first step to improve the course will be helping the students to develop the skills to “see” the abstract vector electric and magnetic fields, and be able to use some field simulation software, and work on hands-on projects in the area of transmission-line, wave-guiding structures, and antenna radiation. In this way, the engineering students will have the basic understanding of the important and recent EM applications.

The EM course was first based on the textbook, Engineering Electromagnetics 7th edition by William H. Hayt Jr. and John A. Buck¹. Later it is replaced by Electromagnetics for Engineers² by Fawwaz T. Ulaby because the latter is relatively easy to follow and includes more working examples and application introductions. In each books, there’s an accompanying disk containing solved problems from end-of-chapter problems, exercises, interactive modules and demonstrations for spatial display of field distribution. These visual aid features are really helpful for the students to learn the EM course without necessarily from the “mathematically demanding” and “abstract” nature. Some reference books^{3,4} emphasis on using Math tools to produce the visual features on the vector field, for example, “fundamental of electromagnetics with Matlab” by K. E. Lonngren and S.V. Savov.

Introducing the visual tools

The vector analysis of the electric and magnetic fields not only included the vector algebra of addition, subtraction and multiplication, but also involve the differentiation and integration vector calculus, the vector operators of gradient, divergence and curl, and application of the divergence theorem and Stokes’s theorems. The connection between the physical phenomena and the math is hardly an instinct for students struggling with the math. To help those students who may not have a sound knowledge of vector calculus, the visualization tool and demonstration are important. There are extensive reports on computing and visualization the EM concepts from past published papers⁵⁻¹⁰. In this paper, the basic software used for computing and demonstrating the EM fields are Matlab^{11,12} and Mathematica¹³ which provide features of vector operation and graphical demonstration. Meanwhile, introduction of commercial EM simulation software is essential, because of the state-of-art computation power of the softwares. The software normally contains the graphic features and post-processor to show the complex EM field distribution from a complex structure. When a field is too complicated or is impossible to obtain an analytical solution, the numerical solution from the software takes over. Other advantages of the commercial software include faster solution and shorter design cycle. These practical tools can help student get a better idea of engineering design and project completion. There are many softwares available for EM field simulation. For beginners, Maxwell 2D/3D

solver is a good choice. They are good to learn since the design features are similar to HFSS, a very popular software from Ansoft company.

Matlab and Mathematica

The mathematical softwares like Matlab and Mathematica can be used for vector operations. These two have the 2D and 3D plotting capabilities, which can be used to illustrate the concepts of static and dynamic EM fields, wave propagation, transmission lines, and radiation. Introducing those math tools is essential to provide visual aids and better understanding of the EM concepts, and enhance students' programming skills to solve engineering EM problems.

(a) Vector algebra and calculus

Both Matlab and Mathematica can do vector analysis. In addition, Mathematica can find the EM fields in analytic form (with additional toolbox, Matlab can solve problems analytically too). One thing worth of mentioning is that both Mathematica and Matlab functions are case-sensitive. To use Mathematica, start with the command `<<Calculus`VectorAnalysis`` to load the package. Then use command `SetCoordinates[system[names]]` to specify a coordinate system and the names of the coordinates. There are 14 different 3-D coordinate systems that can be assigned. For example: `SetCoordinates[Spherical[r, θ , ϕ]]` will set a spherical coordinate system with coordinate names r , θ and ϕ . The three most commonly used coordinate systems are the Cartesian (rectangular), the Cylindrical and the Spherical. Table 1 shows the summary for the common vector analysis commands from the two softwares.

The coordinate transform is always a hard task for the students to perform. Both Mathematica and Matlab have built-in functions for the transform. `CoordinatesToCartesian[{1, Pi/2, Pi/4}, Spherical]` can change the coordinates from the Spherical to the Cartesian. There are other functions which can perform similar operations. Table 2 and 3 list the commands from Matlab and Mathematica. Mathematica shows more flexibility in the transformation of coordinate systems.

Math operation	Mathematica Functions	Matlab Commands
dot product(\mathbf{g})	DotProduct[]	dot()
cross product(\times)	CrossProduct[],	cross()
the gradient(∇)	Grad[]	gradient()
divergence($\nabla\mathbf{g}$)	Div[]	divergence()
curl($\nabla \times$)	Curl[]	curl()
Laplacian (∇^2)	Laplacian[].	del2()

Table 1. The vector analysis functions in Mathematica and Matlab

Coordinates Transform	Matlab Commands
Cartesian to spherical	cart2sph
Cartesian to polar	cart2pol
polar to Cartesian	pol2cart
spherical to Cartesian	sph2cart

Table 2. Coordinate system conversion commands in Matlab

Coordinates Transform	Mathematica Functions
To Cartesian from arbitrary coordinates	CoordinatesToCartesian[pt,coordsys]
From Cartesian to arbitrary coordinates	CoordinatesFromCartesian[pt,coordsys]
To Cartesian from default coordinates	CoordinatesToCartesian[pt]
From Cartesian to default coordinates	CoordinatesFromCartesian[pt]

Table 3. Coordinate system conversion commands in Mathematica

(b) Graphical demonstration

Both Mathematica and Matlab have powerful features to generate 2D and 3D plots. The commands are too many to be listed completely here. Some of the most important features are selected to be discussed in the following.

In Mathematica, the graphics package Graphics`PlotField` can plot 2D vector fields while the package Graphics`PlotField3D` can plot 3D vector field. For example, PlotVectorField[{Sin[x], Cos[y]},{x,0,π},{y,0,π}] produces a vector field in Fig. 1(a), while PlotVectorField3D[{y,-x,0}/z,{x,-1,1},{y,-1,1},{z,1,3}] generates a 3D vector field as shown in Fig 1(b):

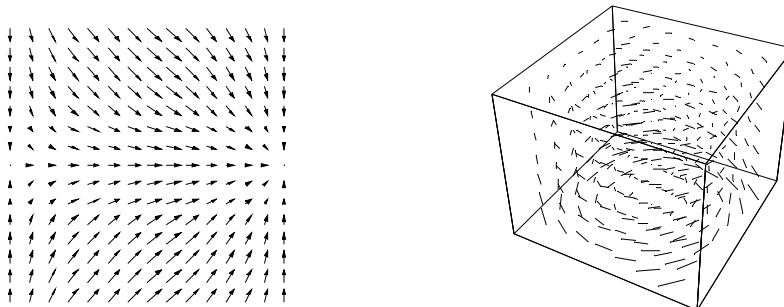

Figure 1. Using Mathematica: (a) The 2D vector plot. (b) The 3D vector plot.

However the vector field plots are only be done in rectangular coordinate. To add the features of plotting vector fields in cylindrical and spherical coordinates, some programming is needed.

Appendix A shows two examples on how to write new functions to plot vector fields in 2D and 3D in cylindrical coordinates.

Matlab functions “quiver” and “quiver3” can also plot vector fields. For example, to plot vector field defined by $\sin(x)$ and $\cos(y)$ in the region $x \in (0, \pi)$ and $y \in (0, \pi)$, a matrix needs to be generated: $[x,y]=\text{meshgrid}(0:0.1:\pi,0:0.1:\pi)$. So a point is defined by any value of (x,y) from the matrix. The vector is defined by component from vectors (u,v) , where $u=\sin(x)$, and $v=\cos(y)$. Then by using the command $\text{quiver}(x,y,U,V)$, vectors at the coordinates specified by corresponding (x,y) are plotted for all the points. Similarly, 3D vector field defined by $(y,-x,0)/z$ in the region $x \in (-1,1)$, $y \in (-1,1)$ and $z \in (1,3)$ is generated by using quiver3 . The commands used are: $z=\text{linspace}(1,3,5)$; $y=\text{linspace}(-1,1,5)$; $x=\text{linspace}(-1,1,5)$; $[X,Y,Z]=\text{meshgrid}(x,y,z)$; $W=0./Z$; $V=-X./Z$; $U=Y./Z$; $\text{quiver3}(X,Y,Z,U,V,W)$. Figure 2 shows the vector field plots, which are similar to the ones generated by Mathematica in Fig. 1.

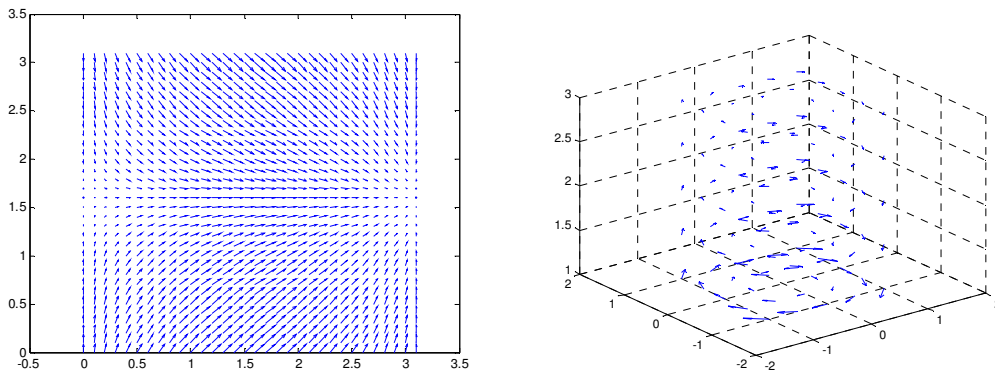

Figure 2. Using Matlab: (a) The 2D vector plot. (b) The 3D vector plot.

(c) Graphical demonstrations for EM applications

In the one-semester syllabus for EM course, following the vector algebra and calculus, the topics include Coulomb’s law, Biot-Savart law, Gauss’s law, Amepere’s law, charge and current distributions, force and energy, potential, conductors and dielectrics, and boundary conditions. In the dynamic field, Farady’s law, and the Maxwell’s equations are introduced, which have some modification from the laws for static field. There are many demonstrations for the field study, for example, the electric field due to charge distribution, and magnetic field due to current distribution. The field can be obtained from vector calculus and plotted by using the software.

Following the field concepts, the applications on EM waves are introduced, including the wave propagation, reflection, transmission, radiation, and transmission line. To show the power of graphical capability of the software, antenna radiation pattern generated by Mathematica are shown below. The first example for the radiation of a short-dipole antenna with

$E_{\theta} = \frac{j\eta_0 k(Il)}{4\pi} \frac{e^{-jk\rho}}{\rho} \sin \theta$ is plotted both in 2-D and 3-D are shown in Fig. 3. The field is

different for a long dipole antenna, and the radiation pattern is related to the length of the dipole:

$$F(\theta) = \frac{\cos\left(\frac{kl}{2} \cos \theta\right) - \cos\left(\frac{kl}{2}\right)}{\sin \theta}. \text{ Figure 4 shows the pattern for } L= 3\lambda/2 \text{ and } 2\lambda \text{ respectively.}$$

```
<< Graphics'Graphics'
PolarPlot[{Sin[u]^2,0},{u,0,2 Pi}]
```

```
<<Graphics'ParametricPlot3D'
SphericalPlot3D[Sin[theta]^2,
{theta,0,Pi},{Phi,0,2 Pi}]
```

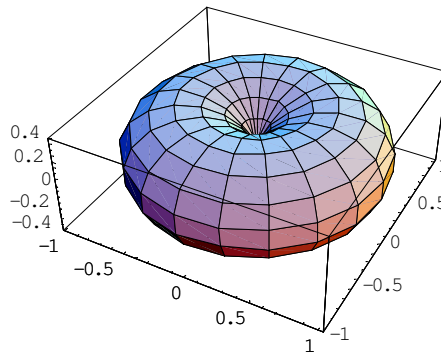
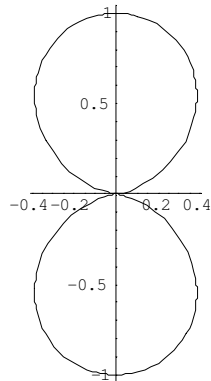

Figure 3. 2D and 3D radiation pattern for a short-dipole antenna.

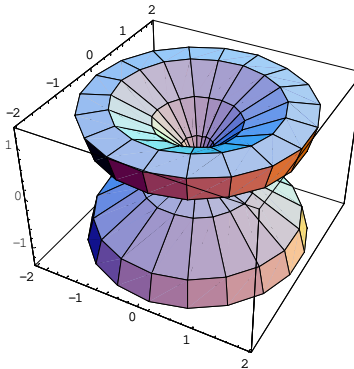
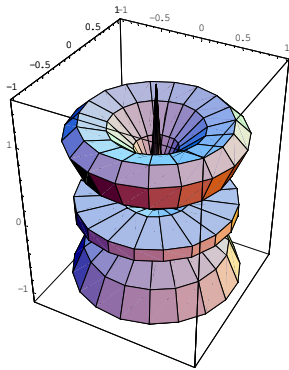

Figure 4. 3D radiation pattern for long dipole antenna with length of $3\lambda/2$ and 2λ .

The commands in Mathematica and Matlab can also incorporate the animation features to demonstrate the dynamic phenomenon. For example, the view and movie commands in Matlab can do the animation. The discussion of those features will not be included in this paper.

Using Maxwell 2D solver in simulating static field problem:

Maxwell 2D solver is a commercial tool in simulating vector electric and magnetic fields. Free downloadable software can be obtained from Ansoft website. It can solve problems in static and frequency time-varying electromagnetic domain, including coupling.

To help the students to know the real-world this practical engineering tool, the project for 2D boundary value problem of finding electric field distribution from a given potential field in a bounded region is assigned. Vector fields from charge sources can be obtained in addition to the analytical solution.

The boundary project is shown in Figure 5, and is described here: The wedge consists of two infinite conducting plates, as shown in the figure below. Calculate the potential by solving Laplace's equation. The boundary condition is $\Phi(\phi = 0) = 0$ and $\Phi(\phi = \phi_0) = V_0$, and assume the wedge is in the free space. (hint: there's no variation in the potential with respect to z and ρ , and the Laplace's equation is in cylindrical coordinates.) Then solve the electric field from the potential field. The theoretical solution based on the ordinary differential equation boundary value problem is $\vec{E} = -V_0 / (\rho \phi_0) \hat{\phi}$.

Use Maxwell 2D solver to model the above problem, assume $V_0 = 10[V]$ and the cross section of the wedge is 1 mm by 15 mm, the ϕ angle can be chosen as 30 degrees. Use post processor to draw the electric field. The following steps were used in order to simulate the problem presented in the first part:

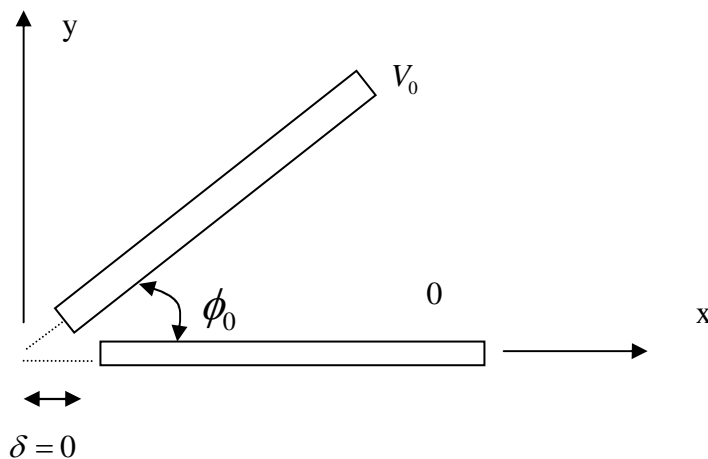

Figure 5. The electric field of conducting wedge in a boundary condition problem.

- 1- Define the model, and draw the plates;
- 2- Setup materials—assign materials conductor properties;
- 3- Setup boundaries;
- 4- Setup executive parameters;
- 5- setup solutions parameters;
- 6- Solve;
- 7- Post process to draw to electric field.

The solution obtained shows that there exists an electric field between the two plates whose magnitude decreases as the ρ value increases. This result is confirmed by the equation obtained earlier, which showed an inverse relationship between the electric field and the ρ value. The values we obtained from the simulations and the ones from the calculations agree well. Figure 6 shows the plots from the post processor of the solver.

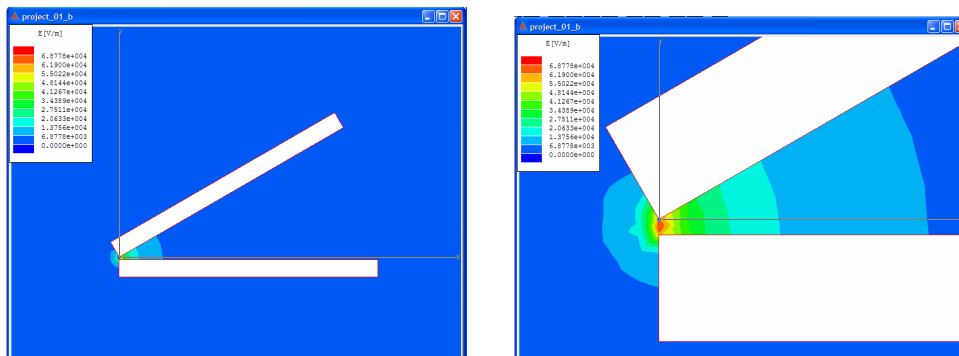

Figure 6. The post processor plot of the electric field for the 2-D wedge.

Conclusions

In this paper, software packages including Mathematica, Matlab and Maxwell 2D solver are discussed for implementation of visual tool for EM field demonstration. Various examples are shown by using the commands or built-in functions in Mathematica and Matlab for vector algebra and calculus. Their capabilities to generate the 2D or 3D field plots including gradient fields, vector fields in different coordinate systems are discussed. It has been shown that the software are powerful to show the physical significance of both the static and dynamic fields and the applications in radiation. Maxwell 2D solver is a commercial software to simulate static and dynamic fields, such as microstrip transmission line, inductor magnetic field and boundary value problems. The above approaches not only enhance students' understanding of EM fields, but also make students get familiar with practical design software and help them have the potential to design components and system with real-world engineering projects.

References

1. Hayt, William H, Jr., Buck, John A. Engineering Electromagnetics, 7th edition, McGraw Hill, 2006.
2. Ulaby, Fawwaz T. Electromagnetics for Engineers, Pearson Prentice Hall, 2005.
3. Ulaby, Fawwaz T. Fundamentals of Applied Electromagnetics, 5th edition, Pearson Prentice Hall, 2007.
4. Lonngren, Karl E. and Savov, Sava V. Fundamentals of Electromagnetics with Matlab, Scitech publishing Inc., 2005.
5. N.Georgieva, "Visualization and involvement: A key to the intuitive understanding of electromagnetics and antenna theory," presented at the *IEEE MTT-S Int. Microwave Symp. Workshop* Phoenix, AZ, May 20–25, 2001.
6. J. C.Rautio, "The impact on education of widely available commercial 3-D planar electromagnetic software," *Comput. Applicat. Eng. Educ.*, vol. 8, no. 2, pp. 51-60, 2000.
7. M. F. Iskander, "Computer-based electromagnetic education," *IEEE Trans. Microwave Theory Tech.*, vol. 41, pp. 920-931, June/July 1993.
8. O.de los Santos Vidal and M. F.Iskander, "Multimedia modules for electromagnetic education," *Comput. Applicat. Eng. Educ.*, vol. 5, no. 4, pp. 257-268, 1997.
9. Assessment-based use of CAD tools in electromagnetic field courses, Popovic, M.; Giannacopoulos, D.D. *Magnetics, IEEE Transactions on* On page(s): 1824- 1827, Volume: 41, Issue: 5, May 2005
10. W. L.Stutzman, "Integration of the personal computer into undergraduate electromagnetic courses," *Comput. Applicat. Eng. Educ.*, vol. 1, no. 3, pp. 223-226, 1993.
11. Hanselman Duane, Littlefield Bruce, Mastering Matlab 7, Pearson Prentice Hall, 2005.
12. Lyshevski, Sergey E. Engineering and Scientific Computations Using MATLAB, Wiley Interscience, 2003.
13. <http://library.wolfram.com/>

Appendix A:

Programming Mathematica to get 2D and 3 D vector fields plot using cylindrical coordinate:

- (a) Plot Vector Field using Cylindrical coordinates to plot a polar vector field $\{f(r,\theta), g[r,\theta]\}$ (θ is the angle) by means of PlotField:

```
<<Graphics`PlotField`;  
angle[x_, y_] := Which[x<0, ArcTan[y/x]+Pi, x*y<0, ArcTan[y/x]+2*Pi, x!=0, ArcTan[y/x],  
x==0, Sign[y]*(Pi/2)];  
Off[Power::infy, Infinity::indet];  
PlotPolarVectorField[{f_,g_}, {r_,theta_}, {x_,x1_,x2_}, {y_,y1_,y2_}, opts___Rule] :=  
PlotVectorField[{f*Cos[theta] - g*Sin[theta], f*Sin[theta] + g*Cos[theta]} /. {r -> Sqrt[x^2 +  
y^2], theta -> angle[x, y]}, {x, x1, x2}, {y, y1, y2}, opts];  
( example : PlotPolarVectorField[{r, Sin[q]}, {r, q}, {x, -1, 1}, {y, -1, 1} ] )
```

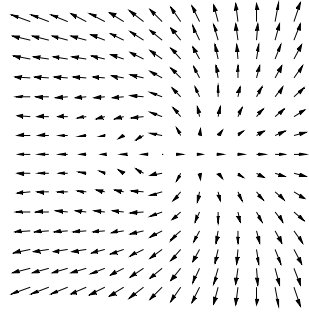

Fig. 7. Plot of 2D vector field in cylindrical coordinate

(b) This uses the same idea to plot a 3D vector field in cylindrical coordinates:

```
<<Graphics`PlotField3D`
PlotCylindricalVectorField[{f_,g_,h_},{r_,q_,z_},{x_,x1_,x2_},
{y_,y1_,y2_},{z_,z1_,z2_},opts_Rule]:=PlotVectorField3D[{f*Cos[q]-g*Sin[q],
f+Sin[q]+g*Cos[q],h}/.{r->Sqrt[x^2+y^2],q->angle[x,y]},{x,x1,x2},{y,y1,y2},{z,z1,z2},opts];
(examples : PlotCylindricalVectorField[{0,1,0},{r,q,z},{x,-1,1},{y,-1,1},{z,0,1}])
```

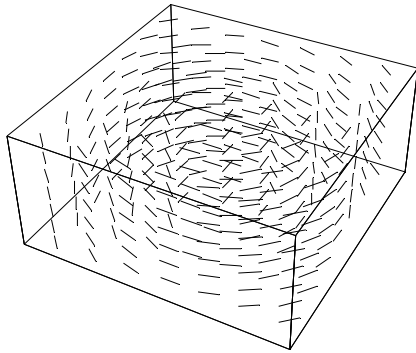

Fig. 8. Plot of 3D vector field in cylindrical coordinate