

# **AC 2007-619: THE EFFECT OF FLUORESCENT LIGHTS ON RFID SYSTEMS OPERATING IN BACKSCATTER MODE**

**Ghassan Ibrahim, Bloomsburg University**

Associate Professor, Electronics Engineering Technology/Bloomsburg University of Pennsylvania, PA

**Jeremy Sensenig, Bloomsburg University**

Undergraduate-Electronics Engineering Technology/ Bloomsburg University of Pennsylvania, PA

# **Effect of Fluorescent Lights on the RFID Systems operating in Backscatter mode**

## **Abstract**

Radio frequency identification (RFID) systems are widely utilized in retail stores and manufacturing environment, where fluorescent lights are commonly used. Fluorescent lights are energized with AC power at certain frequencies depending on their design and go through two cycles of ionization/de-ionization during each power cycle which makes them time varying RF reflectors. There is a possibility that the time varying component of the RFID signal reflected by the fluorescent light may share the same spectrum as similar components originating from the RFID tags, when they are operating in backscatter mode. This dynamic reflection of RF signals may interfere with the operation of the reverse link of the RFID system

A research project was conducted within the Bloomsburg University electronics engineering technology (EET) program to investigate the effect of line and electronic ballast driven fluorescent lights on RFID systems. This opened an opportunity to involve EET students in the research through an independent study course. A sophomore student undertook the task of implementing the experimental measurements under the direction of the instructor/researcher. The experience was enormously beneficial to the student. He learned the concepts of operation of RFID, the operation of various fluorescent light systems and their electronic ballast design, gained knowledge in RF propagation and acquired skills in using RF measurement equipment, RF measurement techniques and data analysis. For a sophomore student the research study gave him an excellent perspective on a modern state of the art technology, and the opportunity to learn what the engineering technologist profession entails.

It became evident from the experimental results that the high speed switching of fluorescent lights by the electronic ballast control voltage modulates the incident RFID carrier signal in a manner similar to that of a modulated backscattered RFID transponder signal, thereby opening the possibility of corrupting the transponder data. Some of the experimental results were presented by the student at the college of science and technology research day as part of his course requirements, where he was questioned on his work by the faculty and students.

This paper will present the experimental results, the methods used in the measurements and the educational outcome of the independent study.

## **Introduction**

Radio Frequency Identification (RFID) has been gaining significant attention in the technology and business arenas. The two main system components are the RFID reader and RFID tags which are attached to items to be identified (merchandise, people, pets, furniture, instruments etc.). An RFID system has a forward (reader to tag) RF link and reverse (tag to reader) RF link. These systems are widely utilized in retail stores and manufacturing environment, where fluorescent lights are commonly used. The fluorescent lights act as RF signal reflectors which may introduce undesirable effects on signals reflected from RFID tags.

Fluorescent lights are energized with AC power at certain frequencies depending on their design and go through two cycles of ionization/de-ionization during each power cycle which makes them time varying RF reflectors. There is a possibility that the time varying component of the RF carrier reflected by the fluorescent light may share the same spectrum as similar components originating from the RFID tags, when they are operating in backscatter mode. This dynamic reflection of RF signals may interfere with the operation of the reverse link of the RFID system.

A research project was conducted within the electronics engineering technology (EET) program to investigate the effect of line and electronic ballast driven fluorescent lights on RFID systems. This opened an opportunity to engage a sophomore EET student in the research through an independent study course. In this paper the fundamentals of RFID and its operation in backscatter mode are presented. The basic concepts of the electronic ballast driven fluorescent lamp are introduced. Then the modulation effects of the fluorescent lights on the backscattered RF signals from the fluorescent lamps and their possible effects on the reverse link RFID signals are explained. The experimental set-up to measure and analyze the effects of the backscattered RF signals from the fluorescent lights is detailed. The results of two experiments, using two different types of electronic ballast driven fluorescent lights, are analyzed. The student role in implementing the experiments and the impact on student knowledge and experience is presented.

### RFID Operating in Backscatter Mode

An RFID system is made of two components: the transponder (tag) located on the object to be identified and the interrogator (reader). The reader contains a radio frequency (RF) transmitter/receiver module, a control unit and an antenna, and can also be interfaced to a computer. The transponder, which is the data carrying device of an RFID system, consists of an antenna and an electronic chip. RFID systems are classified according to the reader operating frequency. The communication between the reader and the transponder is based on a forward (reader to transponder) RF link and reverse (transponder to reader) RF link. The RFID system considered in this paper operates in modulated backscatter mode, operating at the UHF frequency of 915 MHz, which is the US standard<sup>3</sup>; Figure 1 is a block diagram representation of an RFID system operating in backscatter mode.

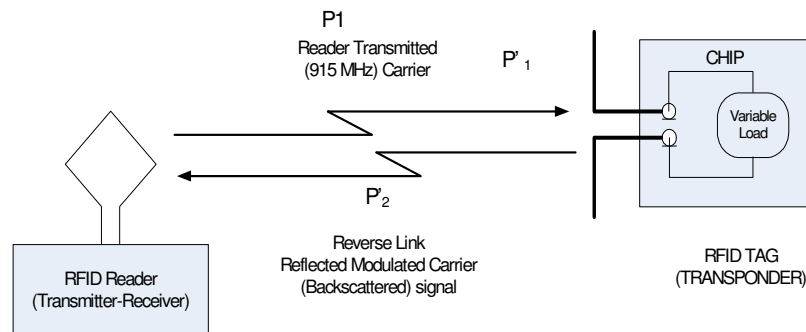

**Figure 1, Modulated Backscatter RFID System**

In this type of RFID system the transponder reflects part of the incident RF power, radiated by the reader, at the scatter aperture of the transponder antenna. Consequently, a small amount of reader power returns to the reader from the transponder. The scatter aperture depends on the relation between the transponder antenna resistance and the antenna terminating resistance  $R_T$ , Figure 2. This relationship is used to send data from the transponder to the reader by varying the input impedance of the transponder, which is the terminating resistance for the antenna, in time with the data stream to be transmitted. The input impedance is varied by switching *additional* impedance  $Z_{mod}$  *off and on*; thereby causing the scatter aperture and thus the power from the transponder to vary in time (modulated) with the data, and thus the name “backscatter modulation”.

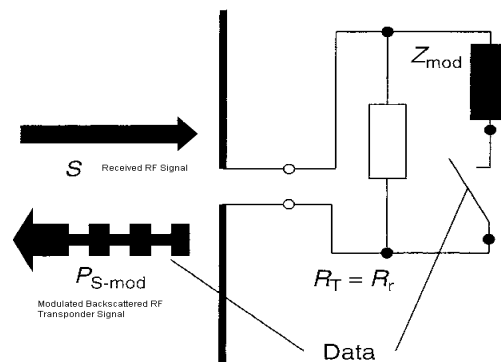
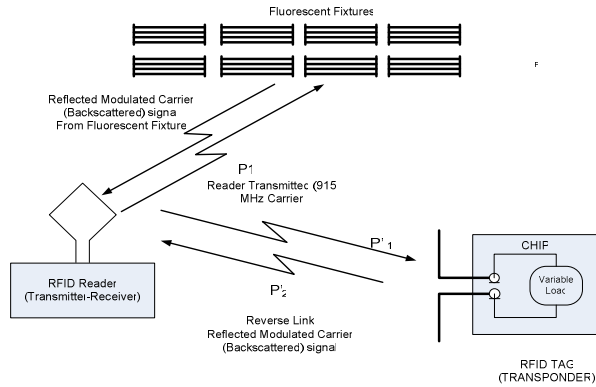

**Figure 2, Transponder Backscatter Modulation<sup>3</sup>**

### **Effects of Electronic Ballasts Driven Fluorescent lights on RFID Backscatter Signals**

Fluorescent lamps operate on alternating gas ionization cycles, which are controlled by the ballast frequency. Between these alternating cycles the ionizing voltage passes through zero twice in each cycle, during which the gas de-ionizes. The detected electrical spectrum of electronic ballast driven fluorescent lamps are shown to contain the fundamental and harmonics of the switching frequency (typically in the range of 20-70 KHz), extending into the MHz range<sup>1</sup>. Other authors have shown that the cyclic ionization and deionization of the gaseous medium causes variations in the medium dielectric. When the fluorescent tube is in the *off* state, it is transparent to the RF signal, and the reflection of incident RF signal will be generated by the tube metal fixture. In its *on* state, the tube absorbs and reflects incident RF signals<sup>2</sup>. In other words, the RF signal is being reflected by a variable impedance medium, switching *on* and *off* between two different loads. This phenomenon may cause the backscattered RF signal from the fluorescent lamp to be modulated by the impedance variation of the tube. This research work investigated this phenomenon which is similar behavior to the backscatter operation of the RFID transponder, and explored its possible effects on UHF RFID transponder signals.

As mentioned above, during the *off* state the fluorescent light is transparent to the incident RF signal and the metallic fixture of the lamp will reflect the signal power; however in the *on* state the gas is ionized and acts as a medium with lossy dielectric attenuating the reflected RF signal. This dynamic reflection of RF signals from the fluorescent lights may interfere with the operation of the reverse link of the RFID system as shown in Figure 3.



**Figure 3, Backscatter Modulated RFID System Operating Environment**

Figure 4 presents a typical spectrum of the RFID reverse link signal<sup>3</sup>, showing the modulated sidebands of the transponder, which contain the transmitted information, together with the reader transmitted carrier.

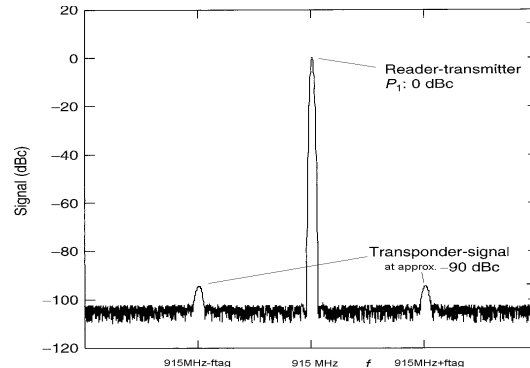

**Figure 4, Backscatter RFID spectrum showing the transponder modulation sidebands**

The reflected carrier signal is not shown since it is much smaller, by orders of magnitude, than the transmitted reader carrier signal. For the transponder to be detected, the sidebands level of the reverse link signal should lie above the noise level of the reader receiver, which is assumed to be 100dB below the level of reader transmitted carrier<sup>3</sup>. However, if the modulated scattering behavior of fluorescent lights is identical to that of an RFID transponder, and generates sidebands of the same order of magnitude as those generated by the transponder, then the reverse link from the RFID transponder to the interrogator receiver will be compromised.

### **Investigating the Effect of Fluorescent Lights on RFID Signals**

To study the backscatter spectrum of a fluorescent lamp fixture and its possible effect on the spectrum of an RFID tag operating in the modulated backscatter mode, two antennas are required. One antenna to transmits a 915 MHz RF carrier signal towards the operating fluorescent light, and the other receives the time varying reflected RF signal from the fluorescent lighting fixture. However, instead of using two antennas the MACOM/ MAANAT0123 dual element circular polarized RFID reader antenna was chosen to transmit and receive the RF signal. The MAANAT0123 is a dual circularly polarized fixed reader antenna, with high gain (6.9 dBi) and broad beam-width (66°). The experimental set up is shown in Figure 5. The transmitted signal

frequency is 915 MHz at 10 dBm. The MACOM/ MAANAT0123 dual element RFID antenna is located at a distance of 2 feet (60 cms) from the fluorescent fixture. The signal generator Agilent E4422B used as the signal source is connected to one input of the antenna, and the Agilent E4404B spectrum analyzer is connected to the antenna receive output.

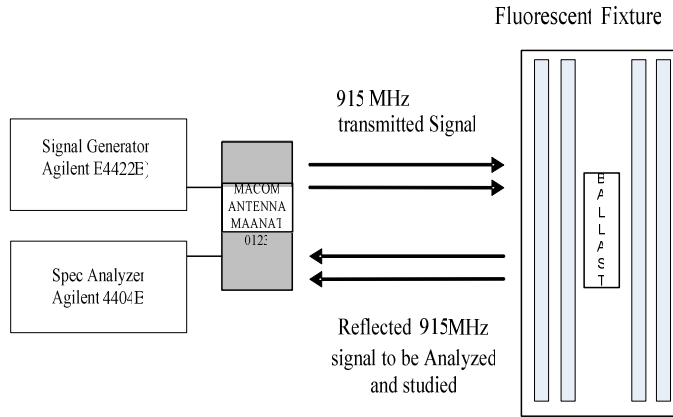

**Figure 5, Experimental Setup**

## The Experiments

### Experiment 1

In the first experiment, using the setup shown in Figure 5, the fluorescent fixture “FL1” used was an “Advanced” electronic ballast model Centinum ICM-4P32-SC and four T8 32 W lamps. The transmitted signal frequency was set at 915 MHz and output power of 10 dBm. The RBW, VBW, and input attenuation of the spectrum analyzer were carefully set to precisely and clearly identify and locate the embedded backscattered spectrum with a good signal resolution. Both the signal generator and the analyzer were synchronized through the 10 MHz signal. Then the following measurements were carried out:

- With fluorescent *off*, and the transmitted signal directed at the fluorescent fixture from a distance of 60 cms, the reflected RF signal spectrum is shown in Figure 6.

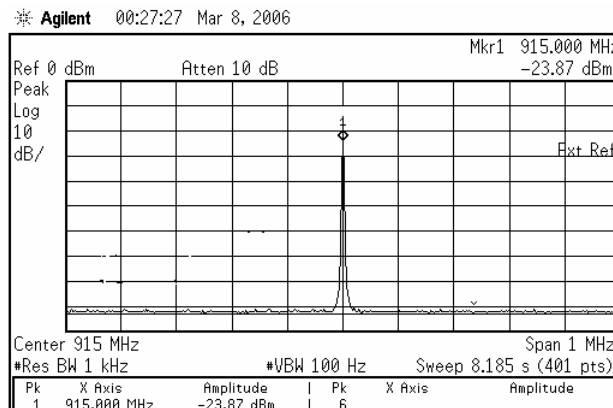

**Figure 6, Reflected 915 MHz signal with fluorescent *off***

- With the fluorescent *on*, the spectrum of the reflected signal is shown in Figure 7. Note that RBW=1 KHz and VBW= 100 Hz, with a frequency span of 1 MHz around the carrier frequency of 915 MHz. The spectrum shows distinct peaks spaced at 45 KHz bands. The 45 KHz is the fundamental switching frequency of the electronic ballast, which was verified by probing the ballast control voltage.

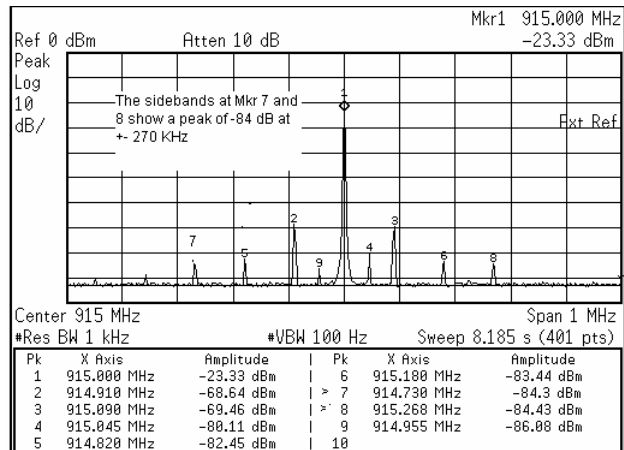

**Figure 7, Reflected 915 MHz signal, using fixture FL1 with four lamps ON, (Modulated sidebands clearly shown spaced at 45 KHZ bands)**

- To investigate the shape of the peaks and what information they carry, the center frequency of the analyzer was set at one of the spectral peaks of 915.045 MHz. The initial results did not show any significant information, Figure 8.

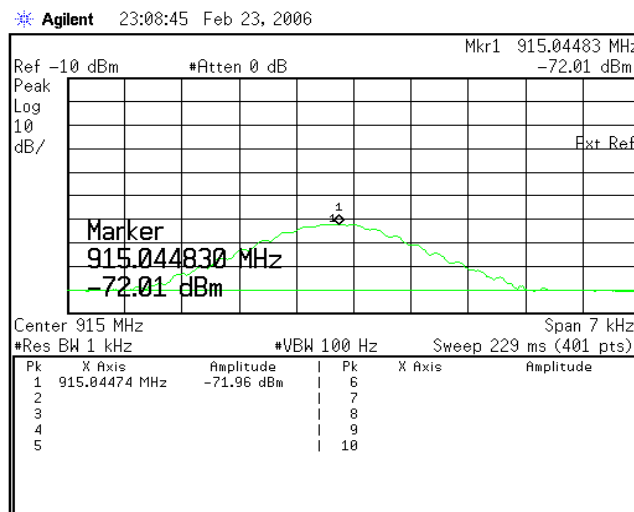

**Figure 8, Reflected 915 MHz signal, using fixture FL1 with four lamps ON, The frequency is centered at 915.045 KHz and span of 7 KHz.**

- To obtain a better resolution in the spectrum, the RBW was reduced to 30 Hz, with a VBW of 10 Hz. Significant information was found as seen in Figure 9. Spectral peaks 120 Hz apart were found to be embedded within the sideband 915.045 MHz frequency, as well as in other higher frequency sidebands.

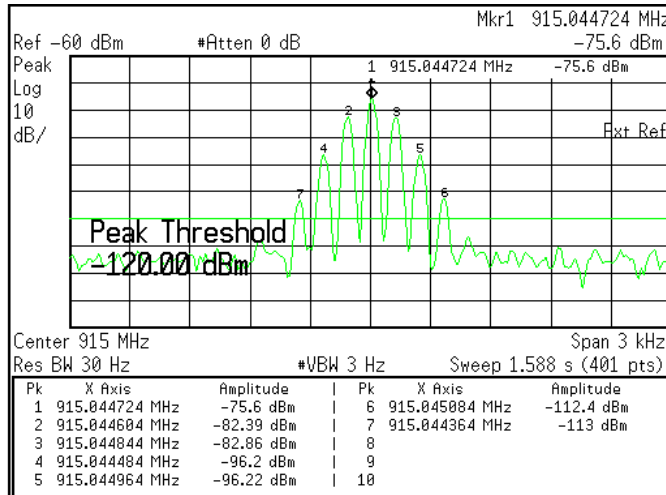

Figure 9, showing peaks 120 Hz apart embedded in the 45 KHz sideband

## Experiment 2

A second experiment was carried out with fixture FL1 replaced by a second fluorescent fixture (FL2 ) controlled by an Advanced electronic ballast model Centinum ICF-2S13-H1-LD using two 13 W four pin quad compact fluorescent lamps (CFL). The spectral analysis of the reflected signal, Figure 10, distinctly shows the carrier amplitude modulation at 68 KHz, and also at multiples of 68 KHz. Centering on the 915.068 MHz sideband with a span of 3 KHz, Figure 11 shows spectral peaks equally spaced around the sideband frequency at 120 Hz intervals. This indicates that the sideband itself is amplitude modulated by the 120 Hz signal and its multiples.

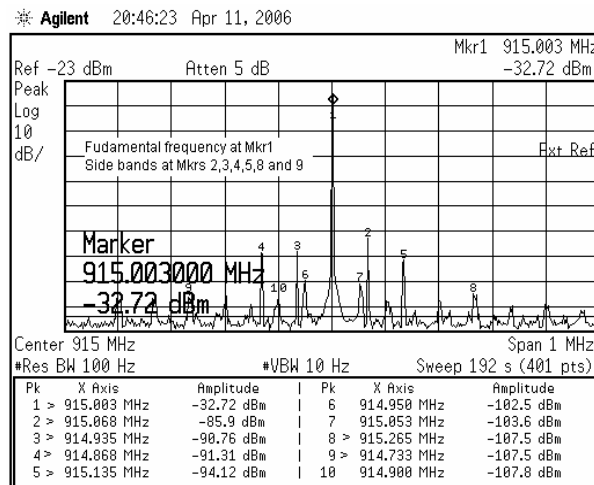
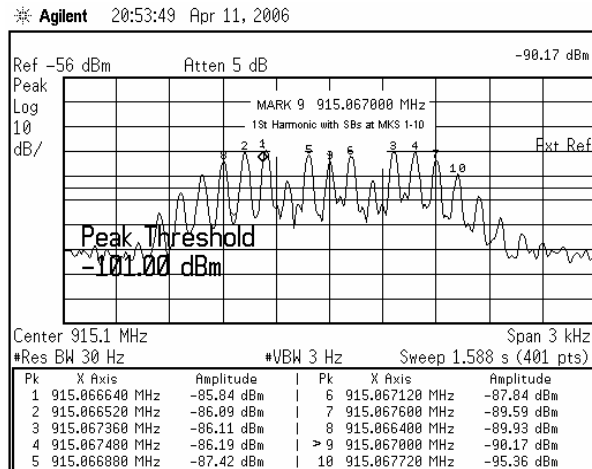
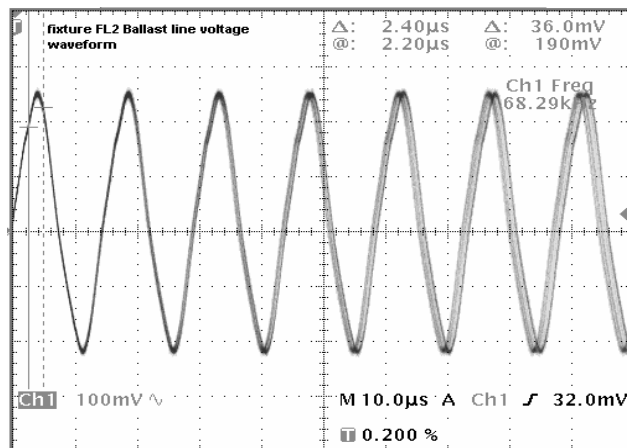

Figure 10, Reflected 915 MHz signal, using fixture FL2 with lamps ON, (Sidebands, marked ">" are spaced at approximately 68 KHz bands)



**Figure 11, Reflected 915 MHz sideband  $\cong$  915.0675 MHz, lamps on, Peaks spaced at 120 Hz are indicated on the sideband.**

The most likely source of the 68 KHz sideband was the ballast control voltage, which is approximately 600 volts. To verify this assumption, the ballast control voltage waveform was recorded, using a Tektronix scope with a differential probe, and the waveform is shown in Figure 12. The measured frequency of this waveform was 68.29 kHz.



**Figure 12, Electronic ballast' (set FL2), control signal waveform with frequency 68 KHz.**

Based on this, it can be seen that the ballast control voltage waveform is in fact the source of 68.KHz frequency, which is the first sideband located on the spectrum of the simulated RFID carrier signal reflected from the fluorescent, Figure 10. The other sidebands are the multiple harmonics of this frequency.

### Student's Role

Prior and during the experiments the student was instructed on the principles of operation of radio frequency identification (RFID) systems and in particular the one operating in the modulated backscatter mode. The student's role was to set up the experimental configurations, perform the measurements, and analyze the results under the supervision of the researcher.

However, to carry out the tasks, he needed to gain the necessary knowledge and skills in radio frequency (RF) communication as well as in RFID. The student was instructed to perform certain pre-set measurements to acquire skills in using the spectrum analyzer to extract the informative data embedded within noise or other unwanted signals. With the level of the received reflected signal being nearly at the instrument noise level, practical skills were required to properly connect the system, and set up the measurement parameters to reduce signal degradation and obtain meaningful measurements. With no background in RF communication, RF equipment, and devices, the student was introduced to the basic concepts of RF effects, and how to handle RF equipment, and devices. He was trained to use RF frequency generators, and an RF spectrum analyzer, and also in the specifics of handling delicate high frequency RF cables and connectors. When using the spectrum analyzer the setting of the following parameters were critical: the input amplitude attenuation, the frequency span range, the resolution bandwidth (RBW), and the video bandwidth (VBW). The determination of the settings was based on the signal level to be detected and its spectrum, and they needed to be skillfully adjusted till a meaningful spectrum was detected. Careful handling of RF cables was emphasized, such as no sharp bends, and no twisting to avoid distortion of the physical structure of the cable. The student was also trained on handling of RF connectors and adapters to interconnect between different parts of the experimental set up. This was strongly emphasized, since novice users of RF equipment and devices tend to ignore and trivialize their handling procedure; thereby, unknowingly, causing extreme damage to these expensive parts and producing unreliable measurements.

After gaining the necessary knowledge and experience the student was on his own self learning track, acquiring and analyzing data, suggesting improvements to the measurement techniques, and proposing solutions to resolve technical problems.

### **Technical Outcome**

It is evident from the experimental results that the high speed switching of fluorescent lights by the electronic ballast voltage modulates the incident RFID carrier signal in a manner similar to that of a modulated backscatter RFID transponder signal. The spectrum consists of the high frequency modulated signal with sidebands located at multiples of 45 KHz for fluorescent set FL1 and multiples of 68 KHz for fluorescent set FL2. These sidebands are themselves modulated at twice the power line frequency of 120 Hz signal, which is a likely product of the ballast's full wave rectified power supply. The levels of these signals are much higher than the noise floor of the reader receiver, which is stated at 100 dBc<sup>3</sup>. This can introduce significant interference into the RFID modulated backscattered transponder signal spectrum, operating at 915 MHz, if it happens to share the same spectral bandwidth

### **Lessons Learned**

This research was carried out in a one semester long, credit bearing independent research course, during which the student learned the basic concepts of RF communication systems and gained industrial skills in RF instrumentation and measurement techniques. He also gained knowledge in RFID systems, modern electronic ballast controlled fluorescent lamps and their backscattering effects on RFID signals. Large numbers of measurements were recorded and analyzed, producing significant results in the process.

When involving a student in a research project it is important to allow sufficient time to instruct him on the basic concepts of the research topic, the required measurement techniques, and skilful handling of the instruments. This proved to be beneficial to the research as well as to the learning process. It is equally important, after acquiring the basic knowledge and skills, that the student be left on his own self leaning track, with guidance from the researcher when needed. It is recommended that undergraduate students in the EET program should be encouraged to pursue independent study research, if possible at the early stages of their education, to learn what the engineering technologist profession entails.

## **Conclusion**

It became evident from the experimental results that the high speed switching of fluorescent lights by the electronic ballast voltage modulates the incident RFID carrier signal in a manner similar to that of a modulated backscatter RFID transponder signal. However, further research is required to analyze the effects this phenomenon has on an actual RFID reverse link signals. During the research priority was given to the student role. He was encouraged, under supervision, and given the freedom to analyze the results, propose solutions, and improve measurement techniques. Through this self learning process the student gained valuable knowledge in modern state of the art technologies and contributed significantly to the research outcome.

## **Bibliography**

1. Ghassemlooy Z., Indoor Optical Wireless Communication Systems-Part I: Review, Quantum Beam Ltd. UK 2003
2. Melancon P. and Lebel J., Effects of Fluorescent Lights on Signal Fading Characteristics for Indoor Radio Channels, IEE Electronic Letters, Vol. 28, Aug. 1992
3. Klaus Finkenzeller, RFID Handbook second edition, WILEY, p145-148, 2003